

Hydraulic Link Clamp

- Model LKA Model TMA-2
- Model LKC Model TMA-1
- Model LKW
- Model LM/LJ



Compact cylinder with built-in link mechanism.

Link design is not required.

Action Description

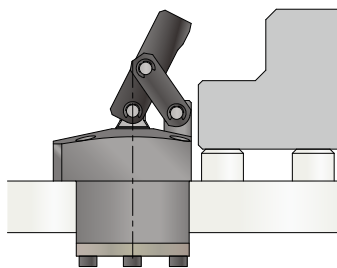

Released State

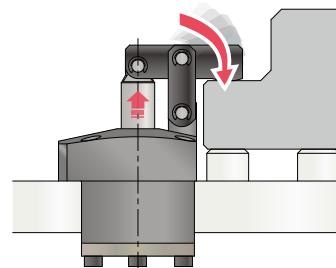

Locked State

Application Examples

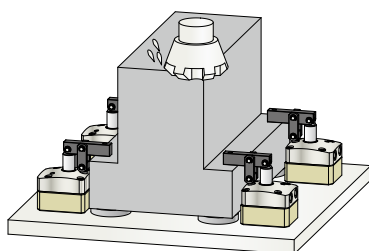

Machining

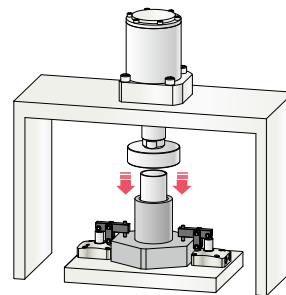

Press Fitting

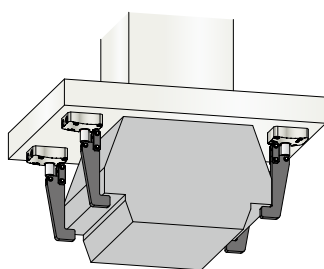

Transfer • Gantry Loader

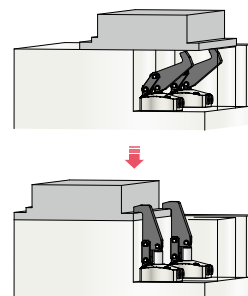

Interference Prevention

New Products



Compact Link Clamp

Model LKC

Compact link clamps for small footprint fixtures.

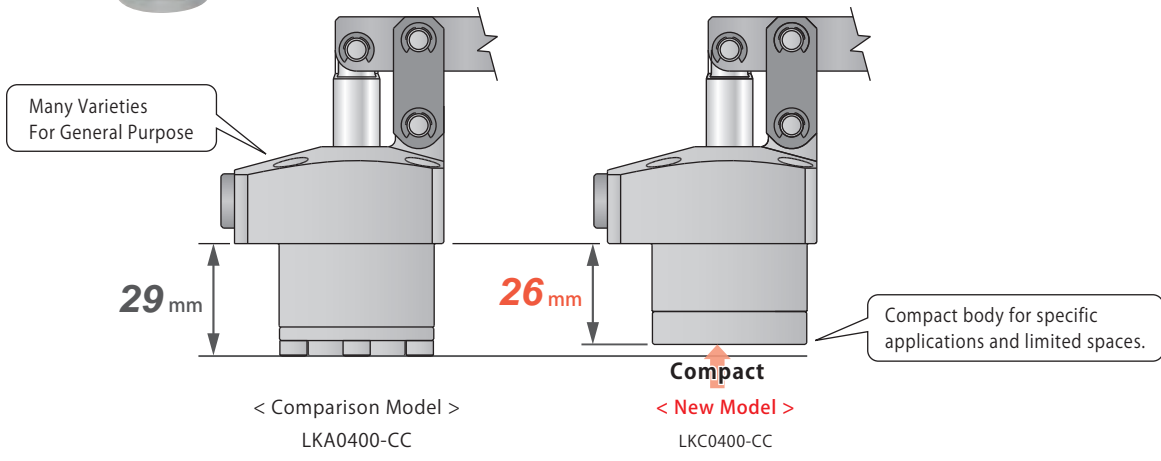

Air Sensing Link Clamp

Model LKW

Clamp-unclamp confirmation with built-in air catch sensor for smaller footprint fixtures.

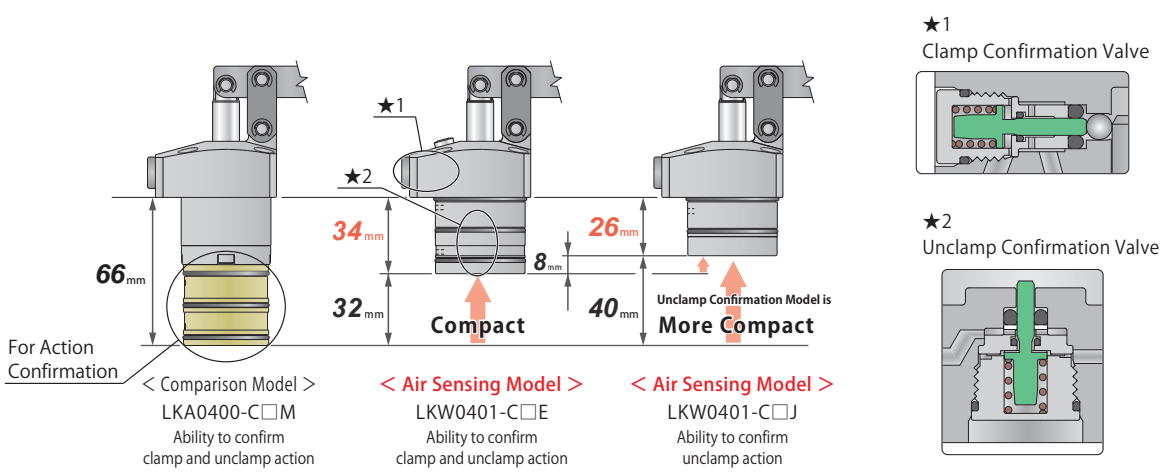

High-Power Link Clamp Hydraulic Double Action

Model LKE

2 sizes smaller with equivalent clamping force. Mechanical lock and hydraulic pressure allow for strong clamping and holding force. Refer to P. 31 for further information.

- High-Power Series
- Pneumatic Series
- Hydraulic Series**
- Valve / Coupler Hydraulic Unit
- Manual Operation Accessories
- Cautions / Others

- Hole Clamp
 - SFA
 - SFC

- Swing Clamp
 - LHA
 - LHC
 - LHS
 - LHW
 - LT/LG
 - TLA-2
 - TLB-2
 - TLA-1

- Link Clamp**
 - LKA
 - LKC
 - LKW
 - LM/LJ
 - TMA-2
 - TMA-1

- Work Support
 - LD
 - LC
 - TNC
 - TC

- Air Sensing Lift Cylinder
 - LLW

- Compact Cylinder
 - LL
 - LLR
 - LLU
 - DP
 - DR
 - DS
 - DT

- Block Cylinder
 - DBA
 - DBC









- Control Valve
 - BZL
 - BZT
 - BZX/JZG

- Pallet Clamp
 - VS
 - VT

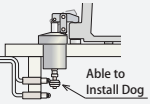
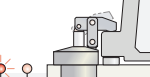
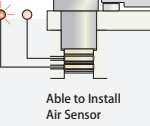

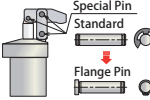



- Expansion Locating Pin
 - VL
 - VM
 - VJ
 - VK





- Pull Stud Clamp
 - FP
 - FQ

- Customized Spring Cylinder
 - DWA/DWB

Low Pressure Model MAX. 7MPa		 Model LKA → P.451	 Model LKC → P.475	 Model LKW → P.487
Classification		Double Action	Double Action Compact	Double Action Built-in Sensing Valve
Operating Pressure Range		0.5~7MPa	0.5~7MPa	0.5~7MPa
Standard Model		External Dimensions → P.463	External Dimensions → P.483	—
Action Confirmation	Double End Rod Option for Dog  Able to Install Dog	External Dimensions → P.465	—	—
	Air Sensing Manifold Option 	External Dimensions → P.467	—	—
	Air Sensing Piping Option  Able to Install Air Sensor	External Dimensions → P.469	—	—
	Built-in Sensing Valve Model	—	—	External Dimensions → P.499
Option	High Strength Link Plate Option  High Strength Link Plate	Allowable offset increases. (External dimension is the same as standard model.)	Allowable offset increases. (External dimension is the same as standard model.)	Allowable offset increases. (External dimension is the same as standard model.)
	Flange Pin with C-type Circlip  Special Pin Standard Flange Pin	★	★	★
Accessories	Lever 	LZK-L → P.474	LZK-L → P.486	LZK-L → P.506
	Manifold Block 	LZY-MD	→ P.1025	—
	Speed Control Valve Plug 	BZL, BZX, JZG		→ P.727

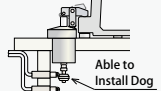
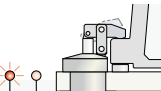
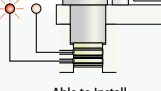
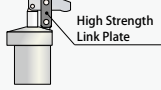
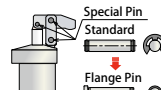
※ Please contact us for detail dimension at ★ part.

High Pressure Model MAX. 35MPa		 Model TMA-2 → P.519	 Model TMA-1 → P.531
Classification		Double Action	Single Action (Spring Release)
Operating Pressure Range		3.5~35MPa	3.5~35MPa
Accessories	Lever 	LZ-LJ3 LZ-LJ2 → P.530	LZ-LJ3 LZ-LJ2 → P.542
	Manifold Block 	TMZ-2MB → P.1027	TMZ-1MB → P.1027
	Speed Control Valve Plug 	BZT, JZG	→ P.727
	G-Thread Fitting 	G-Thread Fitting (Made by Ihara Science) → P.1039	

Low Pressure Model MAX. 7MPa		 Model LM/LJ → P.507
Classification		Single Action (Spring Release)
Operating Pressure Range		2.5~7MPa
Standard Model		External Dimensions → P.515
Action Confirmation	Double End Rod Option for Dog  Able to Install Dog	—
	Air Sensing Manifold Option 	—
	Air Sensing Piping Option  Able to Install Air Sensor	—
	Built-in Sensing Valve Model	—
Option	High Strength Link Plate Option  High Strength Link Plate	—
	Flange Pin with C-type Circlip  Special Pin Standard Flange Pin	—
Accessories	Lever  LZ-LJ1 LZ-LJ2 → P.518	
	Manifold Block  LZ-MS → P.1026	
	Speed Control Valve Plug  BZL, BZX, JZG → P.727	

※ Please contact us for detail dimension at ★ part.



High-Power Link Clamp Hydraulic Double Action

Model **LKE**

2 sizes smaller with equivalent clamping force. Mechanical lock and hydraulic pressure allow for strong clamping and holding force. Refer to P. 31 for further information.

- High-Power Series
- Pneumatic Series
- Hydraulic Series**
- Valve / Coupler Hydraulic Unit
- Manual Operation Accessories
- Cautions / Others
- Hole Clamp
 - SFA
 - SFC
- Swing Clamp
 - LHA
 - LHC
 - LHS
 - LHW
 - LT/LG
 - TLA-2
 - TLB-2
 - TLA-1
- Link Clamp**
 - LKA
 - LKC
 - LKW
 - LM/LJ
 - TMA-2
 - TMA-1
- Work Support
 - LD
 - LC
 - TNC
 - TC
- Air Sensing Lift Cylinder
 - LLW
- Compact Cylinder
 - LL
 - LLR
 - LLU
 - DP
 - DR
 - DS
 - DT
- Block Cylinder
 - DBA
 - DBC
- Control Valve
 - BZL
 - BZT
 - BZX/JZG
- Pallet Clamp
 - VS
 - VT
- Expansion Locating Pin
 - VL
 - VM
 - VJ
 - VK
- Pull Stud Clamp
 - FP
 - FQ
- Customized Spring Cylinder
 - DWA/DWB

Hydraulic Double Action Compact Link Clamp

Model LKC

Low Pressure (0.5~7MPa)

Compact



Index

Hydraulic Link Clamp Digest	P.447
Cross Section	P.476
Action Description	P.476
Model No. Indication	P.477
Specifications	P.478
Performance Curve	
Clamping Force Curve	P.479
Allowable Offset Graph	P.481
External Dimensions	
• Standard Model (LKC)	P.483
Lever Design Dimensions	P.485
Accessories	
• Material Link Lever for LKC	P.486
• Speed Control Valve • Plug (Common Items of Other Models)	P.727
• Manifold Block (Common Items of Other Models)	P.1025
Cautions	
• Notes for Hydraulic Link Clamps	P.543
• Cautions (Common)	P.1043
• Installation Notes • Hydraulic Fluid List • Notes on Hydraulic Cylinder Speed Control Circuit	
• Notes on Handling • Maintenance/Inspection • Warranty	

● Cross Section

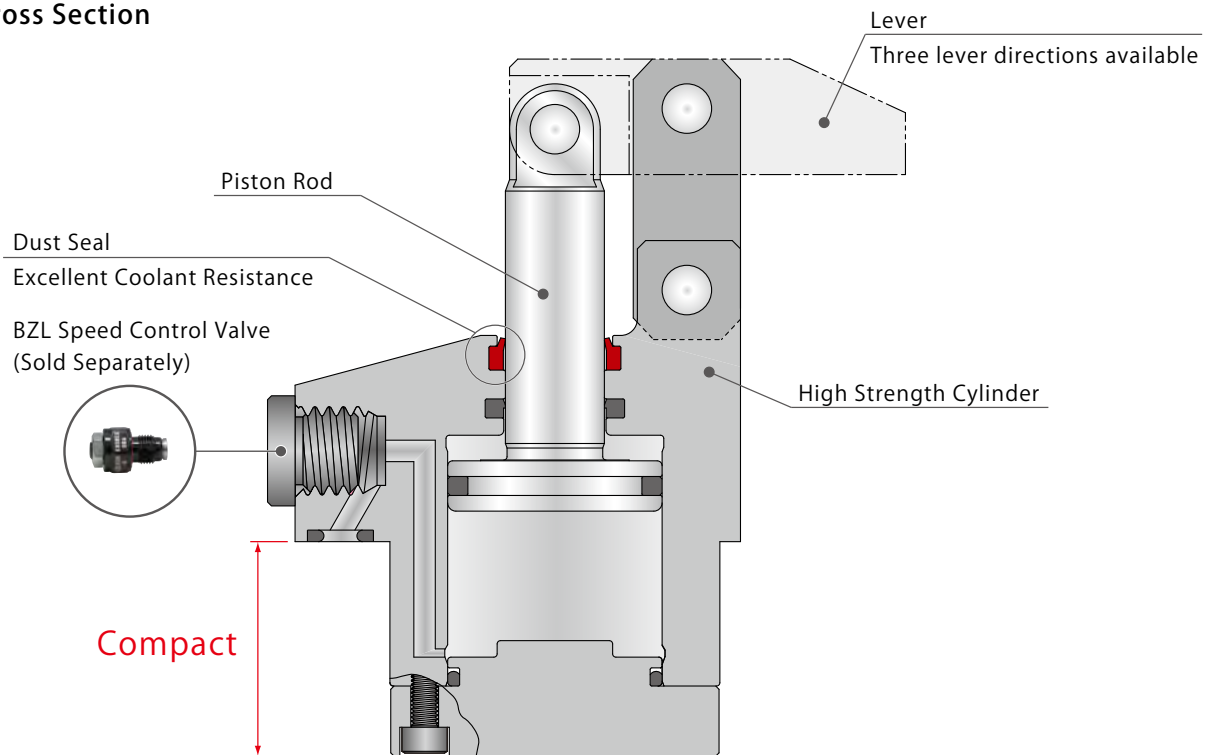

● Compact

The dimension below the flange is shortened to enable smaller footprint fixtures. The compact body enables the internal fitting to limit interference and makes fixture designing more engineer friendly.

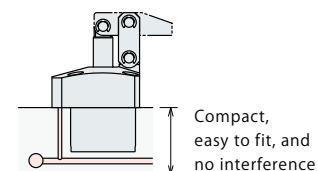

● High Strength Supporting Point

The compact body is able to retain similar clamping and holding forces by including a high strength supporting point within the body cylinder. Its strength is the best in the industry, by way of casting.



● Excellent Coolant Resistance

Our exclusive dust seal is designed to protect against high pressure coolant. It also has high durability against chlorine-based coolant by using a sealing material with excellent chemical resistance.

● Lever in Three Directions Available

Lever positioning is available in three directions; L: Left, C: Center, R: Right. As seen from the port side.

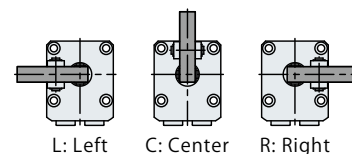

● A Larger Range of Allowable Offset

High strength link plate option is available for larger tolerance.

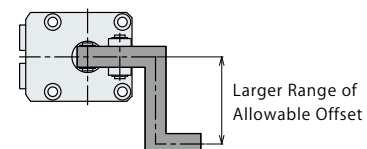

● Able to Attach Speed Control Valve Directly

When fitting the gasket (-C option), it is able to attach the speed control valve with air venting function. (Speed control valve is sold separately.)

● Action Description

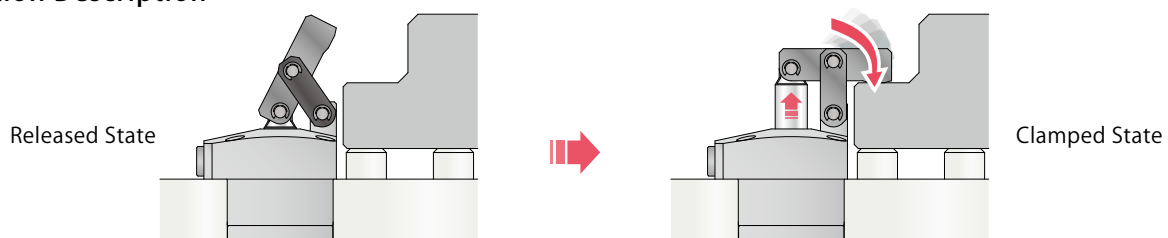

High-Power Series

Pneumatic Series

Hydraulic Series

Valve / Coupler Hydraulic Unit

Manual Operation Accessories

Cautions / Others

Hole Clamp

SFA

SFC

Swing Clamp

LHA

LHC

LHS

LHW

LT/LG

TLA-2

TLB-2

TLA-1

Link Clamp

LKA

LKC

LKW

LM/LJ

TMA-2

TMA-1

Work Support

LD

LC

TNC

TC

Air Sensing Lift Cylinder

LLW

Compact Cylinder

LL

LLR

LLU

DP

DR

DS

DT

Block Cylinder

DBA

DBC

Control Valve

BZL

BZT

BZX/JZG

Pallet Clamp

VS

VT

Expansion Locating Pin

VL

VM

VJ

VK

Pull Stud Clamp

FP

FQ

Customized Spring Cylinder

DWA/DWB

Model No. Indication

LKC **048** **0** - **C** **R** -

1
 2
 3
 4
 5

1 Body Size

040 : $\phi D=40\text{mm}$

048 : $\phi D=48\text{mm}$

055 : $\phi D=55\text{mm}$

065 : $\phi D=65\text{mm}$

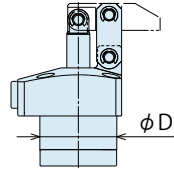

※ Outer diameter (ϕD) of the cylinder.

2 Design No.

0 : Revision Number

3 Piping Method

C : Gasket Option (With G Thread Plug)

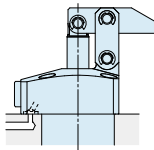

With G Thread Plug
 Able to attach the speed control valve

※ Speed control valve (BZL) is sold separately. Please refer to P.727.

4 Lever Direction

L : Left

C : Center

R : Right

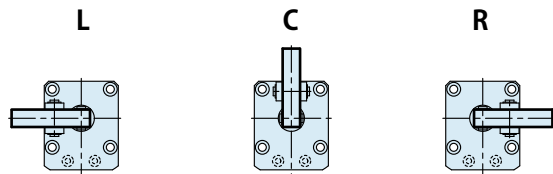

5 Option

Blank : None (Standard)

H : High Strength Link Plate (Increase in Allowable Offset)

K : Flange Pin with C Type Circlip

※ Please contact us for a combination of option.

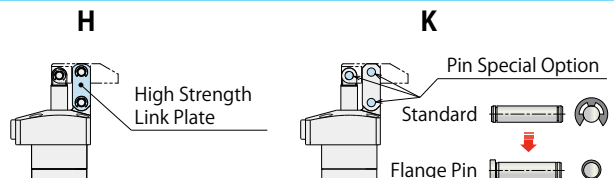

Specifications

Model No.		LKC0400-C□-□	LKC0480-C□-□	LKC0550-C□-□	LKC0650-C□-□
Cylinder Area for Locking	cm ²	5.31	7.07	9.62	15.9
Clamping Force (Calculation Formula) ※ ¹		$F = \frac{7.64 \times P}{L-16}$	$F = \frac{11.76 \times P}{L-18.5}$	$F = \frac{18.18 \times P}{L-21}$	$F = \frac{35.06 \times P}{L-24.5}$
	kN				
Cylinder Inner Diameter	mm	φ26	φ30	φ35	φ45
Rod Diameter	mm	φ12	φ14	φ16	φ20
Cylinder Capacity	Lock	10.9	16.6	25.0	46.9
	Release	8.6	13.0	19.8	37.7
	cm ³				
Full Stroke	mm	20.5	23.5	26	29.5
Lock Stroke	mm	17.5	20.5	23	26.5
Extra Stroke	mm	3	3	3	3
Maximum Operating Pressure	MPa	7.0			
Minimum Operating Pressure ※ ²	MPa	0.5			
Withstanding Pressure	MPa	10.5			
Operating Temperature	°C	0~70			
Usable Fluid		General Hydraulic Oil Equivalent to ISO-VG32			
Mass ※ ³	kg	0.6	1.0	1.3	2.2

- Notes
- ※ 1. F : Clamping Force (kN), P : Supply Hydraulic Pressure (MPa),
L : Distance between the piston center and the clamping point (mm).
 - ※ 2. Minimum pressure to operate the clamp without load.
 - ※ 3. Mass of single clamp without the link lever.
 1. Please refer to P.543 for cautions and tightening torque when mounting the cylinder body.

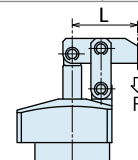

High-Power Series

Pneumatic Series

Hydraulic Series

Valve / Coupler Hydraulic Unit

Manual Operation Accessories

Cautions / Others

Hole Clamp

SFA
SFC

Swing Clamp

LHA
LHC
LHS
LHW
LT/LG
TLA-2
TLB-2
TLA-1

Link Clamp

LKA
LKC
LKW
LM/LJ
TMA-2
TMA-1

Work Support

LD
LC
TNC
TC

Air Sensing Lift Cylinder

LLW

Compact Cylinder

LL
LLR
LLU
DP
DR
DS
DT

Block Cylinder

DBA
DBC

Control Valve

BZL
BZT
BZX/JZG

Pallet Clamp

VS
VT

Expansion Locating Pin

VL
VM
VJ
VK

Pull Stud Clamp

FP
FQ

Customized Spring Cylinder

DWA/DWB

Clamping Force Graph

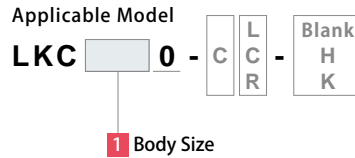
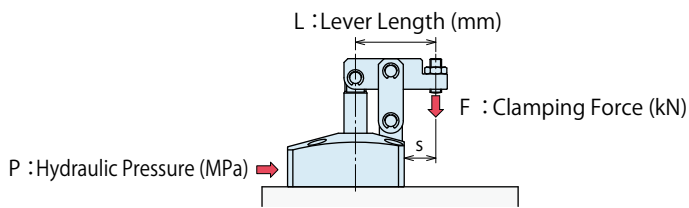

(Example) When using LKC0480,
Supply Hydraulic Pressure 5.0MPa, Lever Length L=42mm, the clamping force is about 2.6kN.

Notes

- Tables and graphs shown are the relationships between the clamping force (kN) and supply hydraulic pressure (MPa).
 - Cylinder output (when L=0) cannot be calculated from the calculation formula of clamping force.
 - Using in the non-usable range may damage the clamp and lead to fluid leakage.
- ※1. F: Clamping Force (kN), P: Supply Hydraulic Pressure (MPa), L: Lever Length (mm)

LKC0400		Clamping Force Calculation Formula ※1 (kN) $F = (7.64 \times P) / (L - 16)$									
Hydraulic Pressure (MPa)	Cylinder Force (kN)	Clamping Force (kN) Lever Length L(mm)								Non-Usable Range (mm)	Min. Lever Length (L) (mm)
		L=25	L=30	L=36.5	L=40	L=50	L=60	L=80	L=100		
7	3.8			2.7	2.3	1.6	1.3	0.9	0.7		36.5
6.5	3.5			2.5	2.1	1.5	1.2	0.8	0.6		34
6	3.2			2.3	2.0	1.4	1.1	0.8	0.6		32
5.5	3.0		3.1	2.2	1.8	1.3	1.0	0.7	0.6		29
5	2.7		2.8	2.0	1.6	1.2	0.9	0.6	0.5		27
4.5	2.4	3.9	2.5	1.8	1.5	1.1	0.8	0.6	0.5		26
4	2.2	3.4	2.2	1.6	1.3	0.9	0.7	0.5	0.4		24
3.5	1.9	3.0	2.0	1.4	1.2	0.8	0.7	0.5	0.4		23
3	1.6	2.6	1.7	1.2	1.0	0.7	0.6	0.4	0.3		23
2.5	1.4	2.2	1.4	1.0	0.8	0.6	0.5	0.3	0.3		23
2	1.1	1.7	1.1	0.8	0.7	0.5	0.4	0.3	0.2		23
1.5	0.8	1.3	0.9	0.6	0.5	0.4	0.3	0.2	0.2		23
1	0.6	0.9	0.6	0.4	0.4	0.3	0.2	0.2	0.1		23
0.5	0.3	0.5	0.3	0.2	0.2	0.2	0.1	0.1	0.1		23
Max. Operating Pressure (MPa)		4.5	5.8	7.0	7.0	7.0	7.0	7.0	7.0	7.0	7.0

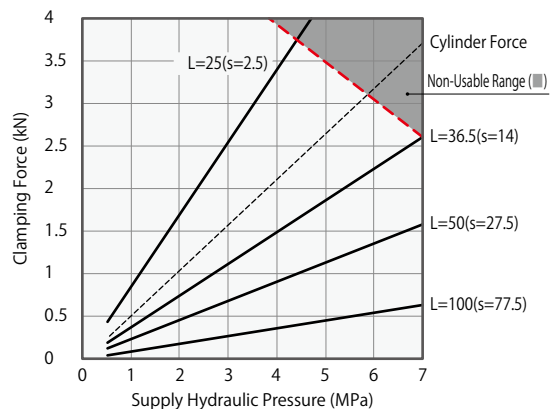

LKC0480		Clamping Force Calculation Formula ※1 (kN) $F = (11.76 \times P) / (L - 18.5)$									
Hydraulic Pressure (MPa)	Cylinder Force (kN)	Clamping Force (kN) Lever Length L(mm)								Non-Usable Range (mm)	Min. Lever Length (L) (mm)
		L=30	L=35	L=42	L=50	L=60	L=80	L=100	L=120		
7	5.0			3.6	2.7	2.0	1.4	1.1	0.9		42
6.5	4.6			3.3	2.5	1.9	1.3	1.0	0.8		39
6	4.3			3.1	2.3	1.8	1.2	0.9	0.7		36
5.5	3.9		4.0	2.8	2.1	1.6	1.1	0.8	0.7		34
5	3.6		3.6	2.6	1.9	1.5	1.0	0.8	0.6		32
4.5	3.2	4.7	3.3	2.3	1.7	1.3	0.9	0.7	0.6		30
4	2.9	4.1	2.9	2.1	1.5	1.2	0.8	0.6	0.5		28
3.5	2.5	3.6	2.5	1.8	1.4	1.0	0.7	0.6	0.5		26
3	2.2	3.1	2.2	1.6	1.2	0.9	0.6	0.5	0.4		26
2.5	1.8	2.6	1.8	1.3	1.0	0.8	0.5	0.4	0.3		26
2	1.5	2.1	1.5	1.1	0.8	0.6	0.4	0.3	0.3		26
1.5	1.1	1.6	1.1	0.8	0.6	0.5	0.3	0.3	0.2		26
1	0.8	1.1	0.8	0.6	0.4	0.3	0.2	0.2	0.2		26
0.5	0.4	0.6	0.4	0.3	0.2	0.2	0.1	0.1	0.1		26
Max. Operating Pressure (MPa)		4.8	5.9	7.0	7.0	7.0	7.0	7.0	7.0	7.0	7.0

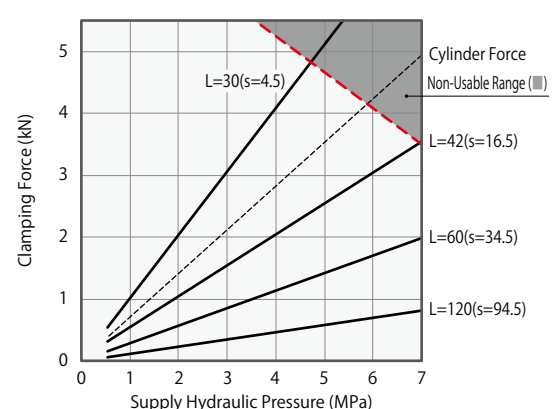

- High-Power Series
- Pneumatic Series
- Hydraulic Series**
- Valve / Coupler Hydraulic Unit
- Manual Operation Accessories
- Cautions / Others

Hole Clamp

- SFA
- SFC

Swing Clamp

- LHA
- LHC
- LHS
- LHW
- LT/LG
- TLA-2
- TLB-2
- TLA-1

Link Clamp

- LKA
- LKC**
- LKW
- LM/LJ
- TMA-2
- TMA-1

Work Support

- LD
- LC
- TNC
- TC

Air Sensing Lift Cylinder

- LLW

Compact Cylinder

- LL
- LLR
- LLU
- DP
- DR
- DS
- DT

Block Cylinder

- DBA
- DBC

Control Valve

- BZL
- BZT
- BZX/JZG

Pallet Clamp

- VS
- VT

Expansion Locating Pin

- VL
- VM
- VJ
- VK

Pull Stud Clamp

- FP
- FQ

Customized Spring Cylinder

- DWA/DWB

LKC0550		Clamping Force Calculation Formula ^{※1} (kN) $F = (18.18 \times P) / (L - 21)$									
Hydraulic Pressure (MPa)	Cylinder Force (kN)	Clamping Force (kN)								Non-Usable Range (mm)	Min. Lever Length (L) (mm)
		Lever Length L (mm)									
		L=35	L=40	L=50	L=60	L=70	L=80	L=100	L=120		
7	6.8			4.4	3.3	2.6	2.2	1.7	1.3	50	
6.5	6.3			4.1	3.1	2.5	2.1	1.5	1.2	46	
6	5.8			3.8	2.8	2.3	1.9	1.4	1.2	43	
5.5	5.3		5.3	3.5	2.6	2.1	1.7	1.3	1.1	39	
5	4.9		4.8	3.2	2.4	1.9	1.6	1.2	1.0	37	
4.5	4.4	5.9	4.4	2.9	2.1	1.7	1.4	1.1	0.9	34	
4	3.9	5.2	3.9	2.6	1.9	1.5	1.3	1.0	0.8	32	
3.5	3.4	4.6	3.4	2.2	1.7	1.3	1.1	0.9	0.7	30	
3	2.9	3.9	2.9	1.9	1.4	1.2	1.0	0.7	0.6	30	
2.5	2.5	3.3	2.4	1.6	1.2	1.0	0.8	0.6	0.5	30	
2	2.0	2.6	2.0	1.3	1.0	0.8	0.7	0.5	0.4	30	
1.5	1.5	2.0	1.5	1.0	0.7	0.6	0.5	0.4	0.3	30	
1	1.0	1.3	1.0	0.7	0.5	0.4	0.4	0.3	0.2	30	
0.5	0.5	0.7	0.5	0.4	0.3	0.2	0.2	0.2	0.1	30	
Max. Operating Pressure (MPa)		4.8	5.7	7.0	7.0	7.0	7.0	7.0	7.0		

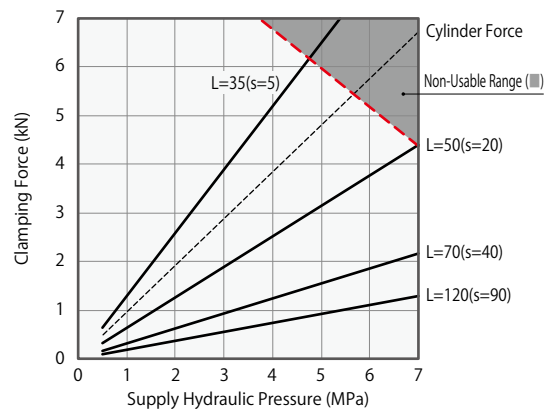

LKC0650		Clamping Force Calculation Formula ^{※1} (kN) $F = (35.06 \times P) / (L - 24.5)$									
Hydraulic Pressure (MPa)	Cylinder Force (kN)	Clamping Force (kN)								Non-Usable Range (mm)	Min. Lever Length (L) (mm)
		Lever Length L (mm)									
		L=40	L=50	L=56.5	L=80	L=100	L=120	L=140	L=160		
7	11.2			7.7	4.5	3.3	2.6	2.2	1.9	56.5	
6.5	10.4			7.2	4.2	3.1	2.4	2.0	1.7	52	
6	9.6			6.6	3.8	2.8	2.3	1.9	1.6	48	
5.5	8.8			6.1	3.5	2.6	2.1	1.7	1.5	45	
5	8.0			5.5	3.2	2.4	1.9	1.6	1.3	42	
4.5	7.2	10.2	6.2	5.0	2.9	2.1	1.7	1.4	1.2	39	
4	6.4	9.1	5.5	4.4	2.6	1.9	1.5	1.3	1.1	37	
3.5	5.6	8.0	4.9	3.9	2.3	1.7	1.3	1.1	1.0	35	
3	4.8	6.8	4.2	3.3	1.9	1.4	1.2	1.0	0.8	35	
2.5	4.0	5.7	3.5	2.8	1.6	1.2	1.0	0.8	0.7	35	
2	3.2	4.6	2.8	2.2	1.3	1.0	0.8	0.7	0.6	35	
1.5	2.4	3.4	2.1	1.7	1.0	0.7	0.6	0.5	0.4	35	
1	1.6	2.3	1.4	1.1	0.7	0.5	0.4	0.4	0.3	35	
0.5	0.8	1.2	0.7	0.6	0.4	0.3	0.2	0.2	0.2	35	
Max. Operating Pressure (MPa)		4.8	6.3	7.0	7.0	7.0	7.0	7.0	7.0		

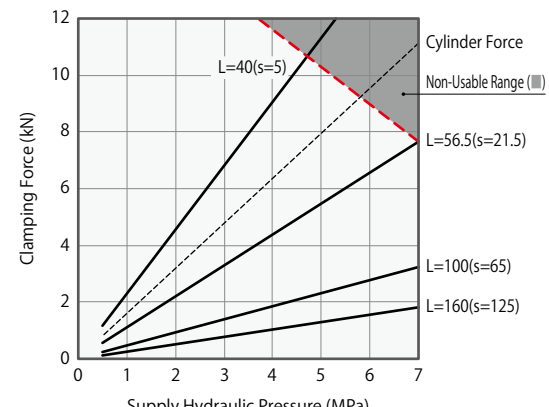

Allowable Offset Graph (Option . . . Blank: Standard)

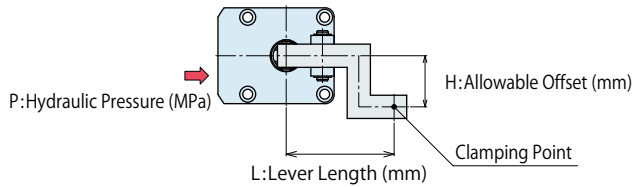

(Example) When using LKC0480-C□
 Supply Hydraulic Pressure 5.0MPa, Lever Length L=80mm
 Allowable Offset is about 10mm.

Applicable Model

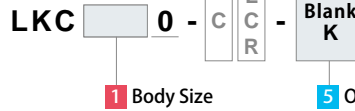

Notes

- Tables and graphs shown are the relationships between the lever length (mm) for supply hydraulic pressure (MPa) and the allowable offset (mm).
- Using the lever beyond allowable offset may cause deformation, galling and fluid leakage etc.
- The tables and graphs are only for reference. The design should be carried out with allowance fully taken into consideration.

LKC0400-C□

Hydraulic Pressure (MPa)	Allowable Offset H(mm)								Non-Usable Range(■)
	Lever Length L(mm)								
	L=25	L=30	L=36.5	L=40	L=50	L=60	L=80	L=100	
7				3	4	5	8	10	
6.5			3	3	5	6	9	12	
6			3	4	5	7	10	14	
5.5		3	4	5	6	8	12	16	
5		3	5	5	8	10	14	19	
4.5		4	5	6	9	12	17	22	
4	3	4	6	7	11	14	20	26	
3.5	3	5	8	9	13	17	24	32	
3	4	6	9	11	16	20	30	39	
2.5	5	8	12	14	20	26	37	49	
2	7	11	16	18	26	34	49	64	
1.5	10	15	22	26	36	47	68	89	
1	15	23	34	40	57	73	106	140	

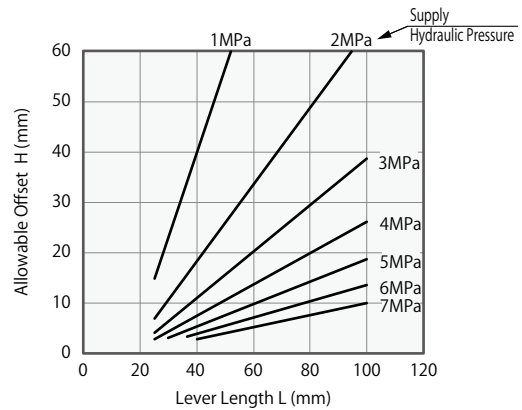

LKC0480-C□

Hydraulic Pressure (MPa)	Allowable Offset H(mm)							Non-Usable Range(■)	
	Lever Length L(mm)								
	L=30	L=35	L=42	L=50	L=60	L=80	L=100		
7				3	4	6	7	9	
6.5				2	3	4	6	9	11
6			3	4	5	8	10	12	
5.5		2	3	5	6	9	12	15	
5		3	4	5	7	10	14	17	
4.5		3	5	6	8	12	16	20	
4	3	4	6	7	10	15	19	24	
3.5	3	5	7	9	12	18	23	29	
3	4	6	8	11	15	22	29	36	
2.5	5	7	10	14	18	27	36	45	
2	7	10	14	18	24	36	47	59	
1.5	9	13	19	25	33	50	66	82	
1	14	21	30	40	52	77	103	128	

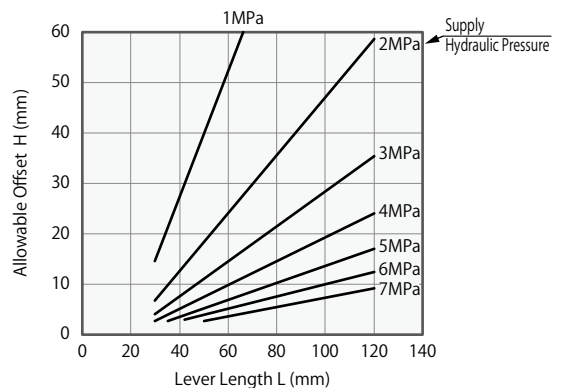

LKC0550-C□

Hydraulic Pressure (MPa)	Allowable Offset H(mm)								Non-Usable Range(■)	
	Lever Length L(mm)									
	L=35	L=40	L=50	L=60	L=70	L=80	L=100	L=120		
7					5	6	7	9	12	
6.5				4	5	7	8	11	14	
6				5	6	8	10	13	16	
5.5				5	7	9	11	15	19	
5			4	6	9	11	13	17	22	
4.5			5	8	10	13	15	21	26	
4	4	6	9	12	15	18	25	31		
3.5	5	7	11	15	18	22	30	37		
3	6	9	13	18	23	27	36	46		
2.5	8	11	17	23	28	34	46	57		
2	11	14	22	30	37	45	60	75		
1.5	15	20	31	41	52	62	84	105		
1	23	31	48	65	81	98	131	164		

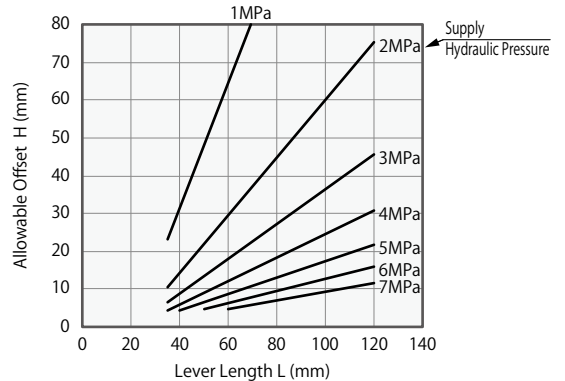

LKC0650-C□

Hydraulic Pressure (MPa)	Allowable Offset H(mm)								Non-Usable Range(■)
	Lever Length L(mm)								
	L=40	L=50	L=56.5	L=80	L=100	L=120	L=140	L=160	
7				5	7	9	11	13	
6.5				4	6	9	11	13	15
6				4	7	10	13	15	18
5.5				4	5	9	12	15	21
5				5	6	10	14	17	25
4.5		3	5	7	12	16	20	25	29
4	4	7	8	14	19	24	30	35	
3.5	5	8	10	17	23	29	36	42	
3	6	10	12	21	29	36	44	51	
2.5	7	12	15	26	36	46	55	65	
2	10	16	20	35	47	60	72	85	
1.5	13	22	28	48	66	83	101	118	
1	21	35	44	76	103	130	157	185	

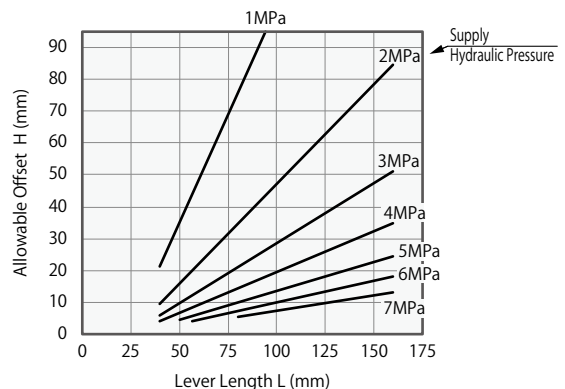

Allowable Offset Graph (Option . . . H : High Strength Link Plate)

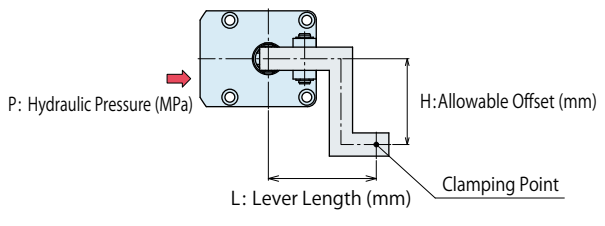

(Example) When using LKC0480-C□-H
 Supply Hydraulic Pressure 5.0MPa, Lever Length L=80mm
 Allowable Offset is about 46mm.

Applicable Model

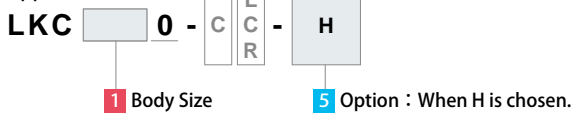

Notes

- Tables and graphs shown are the relationships between the lever length (mm) for supply hydraulic pressure (MPa) and the allowable offset (mm).
- Using the lever beyond allowable offset may cause deformation, galling and fluid leakage etc.
- The tables and graphs are only for reference. The design should be carried out with allowance fully taken into consideration.

LKC0400-C□-H

Hydraulic Pressure (MPa)	Allowable Offset H(mm) Non-Usable Range(■)								
	Lever Length L(mm)								
	L=25	L=30	L=36.5	L=40	L=50	L=60	L=80	L=100	
7				17	24	31	46	60	
6.5			16	18	26	34	49	64	
6			17	20	28	37	53	70	
5.5		13	19	22	31	40	58	76	
5		14	20	24	34	44	64	84	
4.5		16	23	27	38	49	71	93	
4	11	17	26	30	42	55	80	105	
3.5	13	20	29	34	48	63	91	120	
3	15	23	34	40	57	73	106	140	
2.5	18	28	41	48	68	88	128	168	
2	22	35	51	60	85	110	160	210	
1.5	30	47	68	80	113	146	213	279	
1	45	70	102	120	170	220	319	419	

LKC0480-C□-H

Hydraulic Pressure (MPa)	Allowable Offset H(mm) Non-Usable Range(■)							
	Lever Length L(mm)							
	L=30	L=35	L=42	L=50	L=60	L=80	L=100	
7				17	22	33	44	55
6.5			14	18	24	36	47	59
6			15	20	26	39	51	64
5.5		11	16	22	29	42	56	70
5		12	18	24	31	46	62	77
4.5		14	20	26	35	52	68	85
4	11	16	22	30	39	58	77	96
3.5	12	18	25	34	45	66	88	110
3	14	21	30	40	52	77	103	128
2.5	17	25	36	48	63	93	123	153
2	22	31	44	60	78	116	154	192
1.5	29	42	59	79	105	155	205	256
1	43	62	89	119	157	232	308	384

LKC0550-C□-H

Hydraulic Pressure (MPa)	Allowable Offset H(mm) Non-Usable Range(■)								
	Lever Length L(mm)								
	L=35	L=40	L=50	L=60	L=70	L=80	L=100	L=120	
7				28	35	42	56	70	
6.5			22	30	37	45	60	76	
6			24	32	41	49	65	82	
5.5			26	35	44	53	71	89	
5		19	29	39	49	59	79	98	
4.5		21	32	43	54	65	87	109	
4	17	24	36	48	61	73	98	123	
3.5	20	27	41	55	70	84	112	141	
3	23	31	48	65	81	98	131	164	
2.5	28	38	58	78	97	117	157	197	
2	35	47	72	97	122	147	196	246	
1.5	46	63	96	129	162	196	262	328	
1	70	94	144	194	244	293	393	492	

LKC0650-C□-H

Hydraulic Pressure (MPa)	Allowable Offset H(mm) Non-Usable Range(■)							
	Lever Length L(mm)							
	L=40	L=50	L=56.5	L=80	L=100	L=120	L=140	
7				32	44	56	67	79
6.5			20	35	47	60	73	85
6			22	38	51	65	79	92
5.5		19	24	41	56	71	86	101
5		21	26	45	62	78	94	111
4.5	14	23	29	50	69	87	105	123
4	16	26	33	57	77	98	118	139
3.5	18	30	37	65	88	112	135	158
3	21	35	44	76	103	130	157	185
2.5	25	42	52	91	123	156	189	222
2	32	52	65	113	154	195	236	277
1.5	42	70	87	151	206	260	315	369
1	63	104	131	227	309	390	472	554

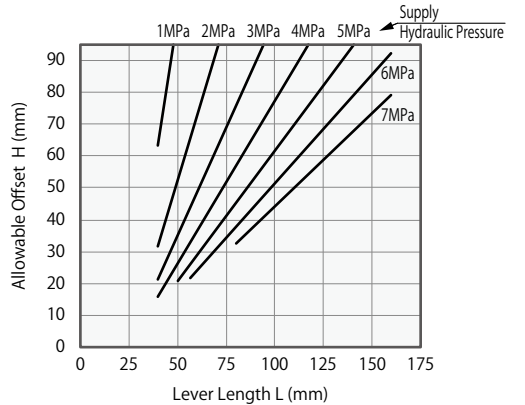
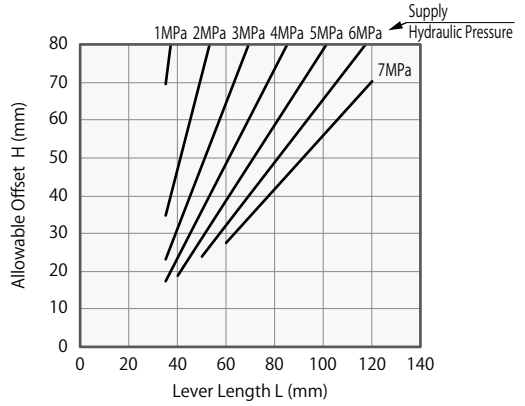
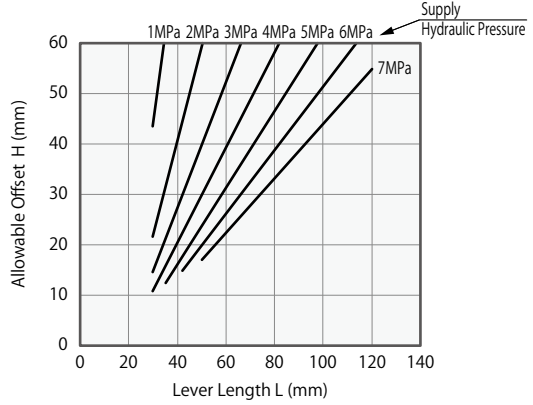
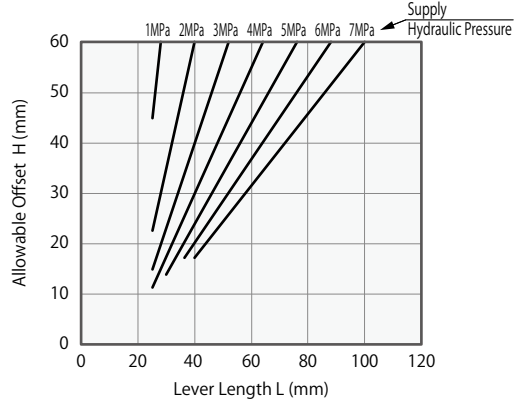

- High-Power Series
- Pneumatic Series
- Hydraulic Series**
- Valve / Coupler Hydraulic Unit
- Manual Operation Accessories
- Cautions / Others

- Hole Clamp
 - SFA
 - SFC

- Swing Clamp
 - LHA
 - LHC
 - LHS
 - LHW
 - LT/LG
 - TLA-2
 - TLB-2
 - TLA-1

- Link Clamp**
 - LKA
 - LKC**
 - LKW
 - LM/LJ
 - TMA-2
 - TMA-1

- Work Support
 - LD
 - LC
 - TNC
 - TC

- Air Sensing Lift Cylinder
 - LLW

- Compact Cylinder
 - LL
 - LLR
 - LLU
 - DP
 - DR
 - DS
 - DT

- Block Cylinder
 - DBA
 - DBC

- Control Valve
 - BZL
 - BZT
 - BZX/JZG

- Pallet Clamp
 - VS
 - VT

- Expansion Locating Pin
 - VL
 - VM
 - VJ
 - VK

- Pull Stud Clamp
 - FP
 - FQ

- Customized Spring Cylinder
 - DWA/DWB

External Dimensions

※ The drawing shows the locked state of LKC-CC.

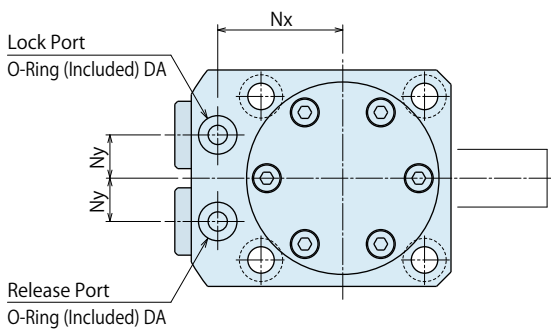
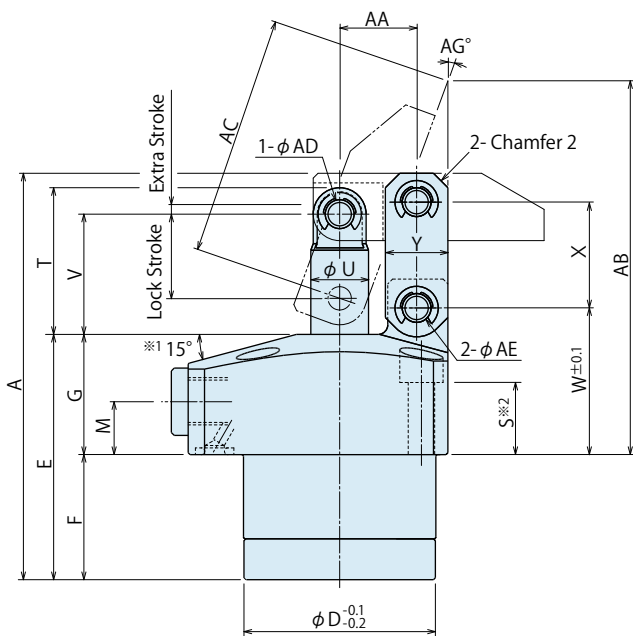
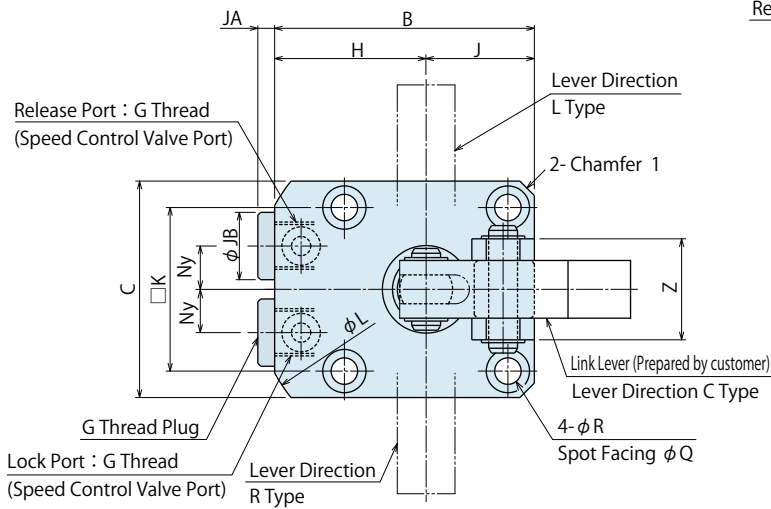

Machining Dimensions of Mounting Area

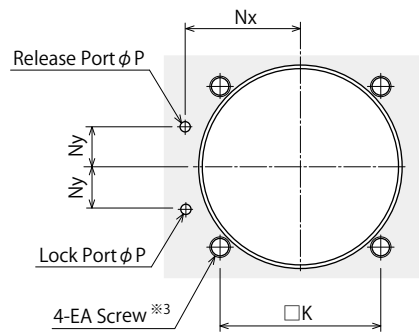

For Blind Hole

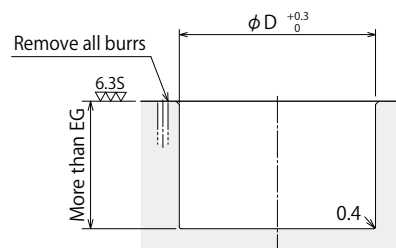

For Through Hole

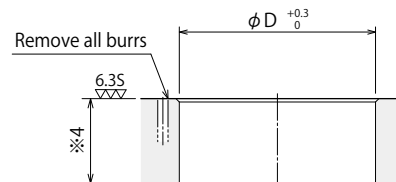

Notes

- ※3. EA tapping depth of the mounting bolt should be decided according to the mounting height referring to dimension 'S'.
- ※4. The depth of the body mounting hole φD should be decided according to the mounting height referring to dimension 'F'.

Notes

- ※ 1. Flange inclination angle is 12° only for LKC0650.
- ※ 2. Mounting bolts are not provided. Please prepare them based on dimension 'S'.
 1. Please use the provided pin (equivalent to φADf6, φAEf6, HRC60) as mounting pin for lever.
 2. Please prepare speed control valve (Refer to P.727) if necessary.

Model No. Indication

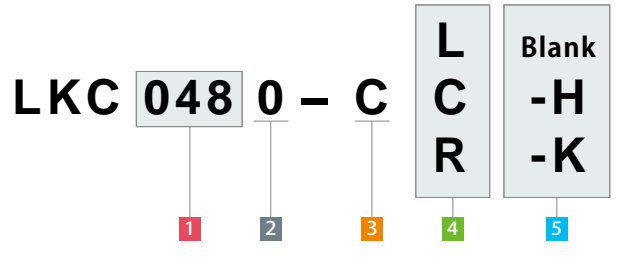

(Format Example : LKC0480-CC, LKC0550-CL-H)

- 1 Body Size
- 2 Design No.
- 3 Piping Method
- 4 Lever Direction
- 5 Option

Notes

1. For option -H, the material of link plate has higher intensity than that of standard plate, and the form of chamfering 2 is round.
2. For option -K, flange pin is used as link pin (3 parts) and C type circlip is used as stop ring.

External Dimensions and Machining Dimensions for Mounting (mm)

Model No.	LKC0400-C□-□	LKC0480-C□-□	LKC0550-C□-□	LKC0650-C□-□
Full Stroke	20.5	23.5	26	29.5
Lock Stroke	17.5	20.5	23	26.5
Extra Stroke	3	3	3	3
A	84.5	95	104	121.5
B	54	61	69	81
C	45	51	60	70
D	40	48	55	65
E	51	56	58.5	67.5
F	26	28	30.5	37.5
G	25	28	28	30
H	31.5	35.5	39	46
J	22.5	25.5	30	35
K	34	40	47	55
L	72	81	88	106
M	11	12	12	13
Nx	26	30	33.5	39.5
Ny	9	11	12	15
P	3	3	3	5
Q	9	9	11	11
R	5.5	5.5	6.8	6.8
S	15	16	13.5	16
T	30.5	35	37.5	45
U	12	14	16	20
V	25	29	31.5	37
W	30.5	34.5	35.5	39
X	22	26	30	35.5
Y	13	13	16	19
Z	21	24	28	37
Chamfer 1	C3	C3	C3	C4
Chamfer 2	C3	C3	C3	C5
AA	16	18.5	21	24.5
AB	77.7	92.4	101.9	111.4
AC	50.2	61.2	71.7	78.7
AD	6	6	6	8
AE	6	6	8	10
AG	20.2	18.9	19.9	20.5
EA (Nominal×Pitch)	M5×0.8	M5×0.8	M6×1	M6×1
EG	26.5	28.5	31	38
JA	3.5	3.5	3.5	4.5
JB	14	14	14	19
Lock Port : G Thread Release Port : G Thread	G1/8	G1/8	G1/8	G1/4
O-Ring	DA	1BP5	1BP5	1BP7

- High-Power Series
- Pneumatic Series
- Hydraulic Series**
- Valve / Coupler Hydraulic Unit
- Manual Operation Accessories
- Cautions / Others
- Hole Clamp
 - SFA
 - SFC
- Swing Clamp
 - LHA
 - LHC
 - LHS
 - LHW
 - LT/LG
 - TLA-2
 - TLB-2
 - TLA-1
- Link Clamp**
 - LKA
 - LKC**
 - LKW
 - LM/LJ
 - TMA-2
 - TMA-1
- Work Support
 - LD
 - LC
 - TNC
 - TC
- Air Sensing Lift Cylinder
 - LLW
- Compact Cylinder
 - LL
 - LLR
 - LLU
 - DP
 - DR
 - DS
 - DT
- Block Cylinder
 - DBA
 - DBC
- Control Valve
 - BZL
 - BZT
 - BZX/JZG
- Pallet Clamp
 - VS
 - VT
- Expansion Locating Pin
 - VL
 - VM
 - VJ
 - VK
- Pull Stud Clamp
 - FP
 - FQ
- Customized Spring Cylinder
 - DWA/DWB

Link Lever Design Dimension

※ Reference for designing link lever.

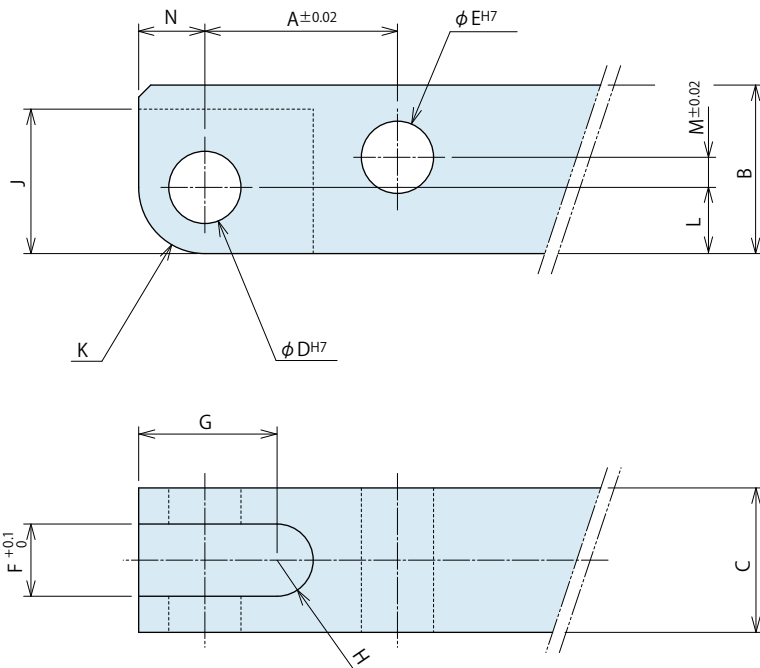

Link Lever Design Dimension List

Corresponding Model No.	(mm)			
	LKC0400	LKC0480	LKC0550	LKC0650
A	16	18.5	21	24.5
B	14	16	20	25
C	12 ⁰ _{-0.3}	12 ⁰ _{-0.3}	16 ⁰ _{-0.3}	19 ⁰ _{-0.3}
D	6 ^{+0.012} ₀	6 ^{+0.012} ₀	6 ^{+0.012} ₀	8 ^{+0.015} ₀
E	6 ^{+0.012} ₀	6 ^{+0.012} ₀	8 ^{+0.015} ₀	10 ^{+0.015} ₀
F	6	6	8	10
G	11.5	13	12.5	16
H	R3	R3	R4	R5
J	12	13	13	17.5
K	R5.5	R6	R6	R8
L	5.5	6	6	8
M	2.5	3.5	6	7.5
N	5.5	6	6	8

Notes

1. Please design the link lever length according to the performance curve.
2. If the link lever is not in accordance with the dimension shown above, performance may be degraded and damage can occur.
3. Please use the attached pin (equivalent to φADf6, φAEf6, HRC60) as the mounting pin for lever.
(Please refer to each external dimension of LKC for the dimensions φAD and φAE.)

Accessory : Material Link Lever

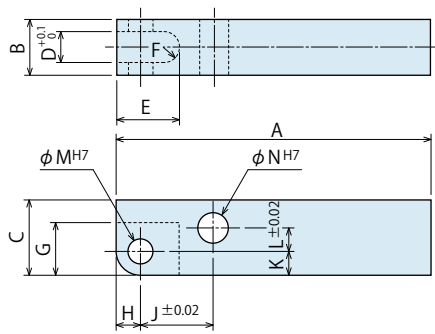

Model No. Indication

LZK 048 0 - L

Size (Refer to the table) Design No. (Revision Number)

(mm)

Model No.	LZK0400-L	LZK0480-L	LZK0550-L	LZK0650-L
Corresponding Model No.	LKC0400	LKC0480	LKC0550	LKC0650
A	75	85	90	105
B	12 _{-0.3} ⁰	12 _{-0.3} ⁰	16 _{-0.3} ⁰	19 _{-0.3} ⁰
C	14	16	20	25
D	6	6	8	10
E	14.5	16	16.5	21
F	R3	R3	R4	R5
G	12	13	13	17.5
H	5.5	6	6	8
J	16	18.5	21	24.5
K	5.5	6	6	8
L	2.5	3.5	6	7.5
M	6 ₀ ^{+0.012}	6 ₀ ^{+0.012}	6 ₀ ^{+0.012}	8 ₀ ^{+0.015}
N	6 ₀ ^{+0.012}	6 ₀ ^{+0.012}	8 ₀ ^{+0.015}	10 ₀ ^{+0.015}

- Notes
1. Material S45C
 2. If necessary, the front end should be additionally machined.
 3. Please use the attached pin (equivalent to ϕ ADf6, ϕ AEf6, HRC60) as the mounting pin for lever.

High-Power
Series

Pneumatic Series

Hydraulic Series

Valve / Coupler
Hydraulic Unit

Manual Operation
Accessories

Cautions / Others

Hole Clamp

SFA
SFC

Swing Clamp

LHA
LHC
LHS
LHW
LT/LG
TLA-2
TLB-2
TLA-1

Link Clamp

LKA
LKC
LKW
LM/LJ
TMA-2
TMA-1

Work Support

LD
LC
TNC
TC

Air Sensing
Lift Cylinder

LLW

Compact Cylinder

LL
LLR
LLU
DP
DR
DS
DT

Block Cylinder

DBA
DBC

Control Valve

BZL
BZT
BZX/JZG

Pallet Clamp

VS
VT

Expansion
Locating Pin

VL
VM
VJ
VK

Pull Stud Clamp

FP
FQ

Customized
Spring Cylinder

DWA/DWB

Cautions

● Notes for Design

- 1) Check Specifications
 - Please use each product according to the specifications.
- 2) Notes for Circuit Design
 - Please read "Notes on Hydraulic Cylinder Speed Control Circuit" on P.1044 to assist with proper hydraulic circuit designing.
 - Ensure there is no possibility of supplying hydraulic pressure to the lock and release ports simultaneously.
- 3) Notes for Link Lever Design
 - Make sure no force is applied to the piston rod except the axial direction. (Make sure the clamp surface and the mounting surface on the workpiece are parallel.) The usage like the one shown in the drawing below will apply a large bending stress to the piston rod and must be avoided.

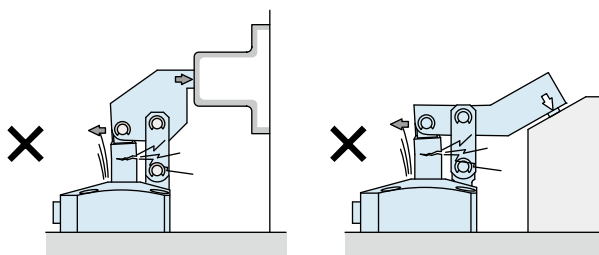

- If offset load is applied on the link part, use it within the allowable range of "Allowable Offset Graph".
- 4) When using on a welding fixture, the exposed area of piston rod and link plate should be protected.
 - If spatter gets onto the sliding surface it may lead to malfunction and fluid leakage.
 - 5) When clamping on a sloped surface on the workpiece.
 - Make sure the clamp surface and the mounting surface on the workpiece are parallel.

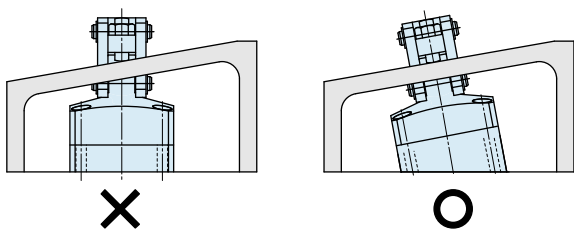

- 6) When using in a dry environment.
 - The link pin can dry out. Grease it periodically or use a special pin. Contact us for the specifications for special pins.
- 7) Notes for LKA-M/N, LKW
 - When using air sensing link clamp (LKA-M/N, LKW), make sure to check the Notes for Design • Installation • Use (Pages shown below).
 - Link clamp with air sensing option LKA-M/N: Refer to P.471.
 - Link clamp with air sensing valve LKW: Refer to P.491.

● Notes on installation.

- 1) Check the fluid to use.
 - Please use the appropriate fluid by referring to the Hydraulic Fluid List (P.1043).
- 2) Mounting / Removing clamp.
 - When mounting the clamp, use hexagon socket bolts as multiple bolt holes for mounting (with tensile strength of 12.9) and tighten them with the torque shown in the chart below. Tightening with greater torque than recommended can depress the seating surface or break the bolt.

	Model No.	Thread Size	Tightening Torque (N·m)
LKA LKC LKW	LKA0360	M4×0.7	4.0
	LKA0400	M5×0.8	8.0
	LKC0400/LKW0400		
	LKA0480	M5×0.8	8.0
	LKC0480/LKW0480		
	LKA0550	M6×1	14
	LKC0550/LKW0550		
	LKA0650	M6×1	14
	LKC0650/LKW0650		
	LM/LJ	LKA0750	M8×1.25
LKA0900		M10×1.5	65
LKA1050		M12×1.75	114
LM0360		M4×0.7	3.2
LM0400		M5×0.8	6.3
LM0480		M5×0.8	6.3
LM0550		M6×1	10
LM0650		M6×1	10
LM0750		M8×1.25	25
LJ0902		M10×1.5	58.8
LJ1052	M12×1.75	98	
TMA	TMA0250	M5×0.8	6.9
	TMA0400	M5×0.8	6.9
	TMA0600	M6×1	11.8
	TMA1000	M8×1.25	25
	TMA1600	M10×1.5	58.8
	TMA2500	M12×1.75	98
	TMA3200	M12×1.75	98

3) Installation / Removal of the Link Lever

- When inserting the link pin, do not hit the pin directly with a hammer. When using a hammer to insert the pin, always use a cover plate with a smaller diameter than the snap ring groove on the pin.

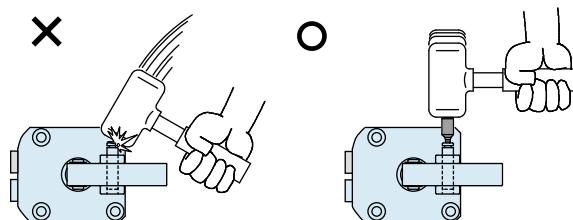

4) Speed Adjustment

- Adjust the speed so that the total operating time is one second or more. If the clamp operates too fast the parts will wear out leading to premature damage and ultimately complete equipment failure.
- Please make sure to release air from the circuit before adjusting speed. It will be difficult to adjust the speed accurately with air mixed in the circuit.
- Turn the speed control valve gradually from the low-speed side (small flow) to the high-speed side (large flow) to adjust the speed.

- 5) Notes on double end rod option (-D) for dog application.
- When installing dog or cam onto rod end, secure the dog or cam and prevent any rotation or torque on the piston rod. Fix the width part at the front of the dog and then mount it. Torque values for the mounting screw are shown in the table below.

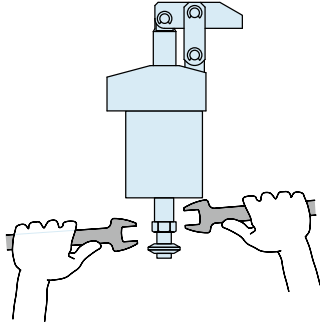

	Model No.	Thread Size	Tightening Torque (N·m)
LKA-D	LKA0360-□□D	M4×0.7	3.2
	LKA0400-□□D	M6×1	10
	LKA0480-□□D	M8×1.25	25
	LKA0550-□□D	M8×1.25	25
	LKA0650-□□D	M8×1.25	25
	LKA0750-□□D	M10×1.5	50
	LKA0900-□□D	M10×1.5	50
	LKA1050-□□D	M10×1.5	50

※ Please refer to P.1043 for common cautions.

- Installation Notes
- Hydraulic Fluid List
- Notes on Hydraulic Cylinder Speed Control Circuit
- Notes on Handling
- Maintenance/Inspection
- Warranty

High-Power Series

Pneumatic Series

Hydraulic Series

Valve / Coupler Hydraulic Unit

Manual Operation Accessories

Cautions / Others

Hole Clamp

SFA
SFC

Swing Clamp

LHA
LHC
LHS
LHW
LT/LG
TLA-2
TLB-2
TLA-1

Link Clamp

LKA
LKC
LKW
LM/LJ
TMA-2
TMA-1

Work Support

LD
LC
TNC
TC

Air Sensing Lift Cylinder

LLW

Compact Cylinder

LL
LLR
LLU
DP
DR
DS
DT

Block Cylinder

DBA
DBC

Control Valve

BZL
BZT
BZX/JZG

Pallet Clamp

VS
VT

Expansion Locating Pin

VL
VM
VJ
VK

Pull Stud Clamp

FP
FQ

Customized Spring Cylinder

DWA/DWB

● Cautions

● Installation Notes (For Hydraulic Series)

- 1) Check the Usable Fluid
 - Please use the appropriate fluid by referring to the Hydraulic Fluid List.
- 2) Procedure before Piping
 - The pipeline, piping connector and fixture circuits should be cleaned by thorough flushing.
 - The dust and cutting chips in the circuit may lead to fluid leakage and malfunction.
 - There is no filter provided with Kosmek' s product except for a part of valves which prevents foreign materials and contaminants from getting into the circuit.
- 3) Applying Sealing Tape
 - Wrap with tape 1 to 2 times following the screw direction.
 - Pieces of the sealing tape can lead to oil leakage and malfunction.
 - In order to prevent a foreign substance from going into the product during the piping work, it should be carefully cleaned before working.
- 4) Air Bleeding of the Hydraulic Circuit
 - If the hydraulic circuit has excessive air, the action time may become very long. If air enters the circuit after connecting the hydraulic port or under the condition of no air in the oil tank, please perform the following steps.
 - ① Reduce hydraulic pressure to less than 2MPa.
 - ② Loosen the cap nut of pipe fitting closest to the clamp by one full turn.
 - ③ Wiggle the pipeline to loosen the outlet of pipe fitting.
Hydraulic fluid mixed with air comes out.

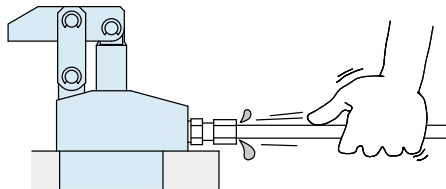

- ④ Tighten the cap nut after bleeding.
- ⑤ It is more effective to bleed air at the highest point inside the circuit or at the end of the circuit.
(Set an air bleeding valve at the highest point inside the circuit.)

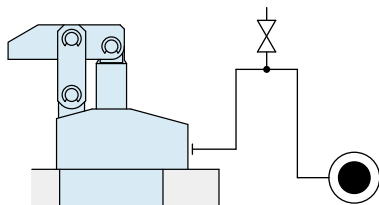

5) Checking Looseness and Retightening

- At the beginning of the machine installation, the bolt and nut may be tightened lightly. Check the looseness and re-tighten as required.

● Hydraulic Fluid List

Maker	ISO Viscosity Grade ISO-VG-32	
	Anti-Wear Hydraulic Oil	Multi-Purpose Hydraulic Oil
Showa Shell Sekiyu	Tellus S2 M 32	Morlina S2 B 32
Idemitsu Kosan	Daphne Hydraulic Fluid 32	Daphne Super Multi Oil 32
JX Nippon Oil & Energy	Super Hyrando 32	Super Mulpus DX 32
Cosmo Oil	Cosmo Hydro AW32	Cosmo New Mighty Super 32
ExxonMobil	Mobil DTE 24	Mobil DTE 24 Light
Matsumura Oil	Hydol AW-32	
Castrol	Hyspin AWS 32	

Note As it may be difficult to purchase the products as shown in the table from overseas, please contact the respective manufacturer.

- High-Power Series
- Pneumatic Series
- Hydraulic Series
- Valve / Coupler Hydraulic Unit
- Manual Operation Accessories
- Cautions / Others

Cautions

- Installation Notes (For Hydraulic Series)
- Hydraulic Fluid List
- Notes on Hydraulic Cylinder Speed Control Circuit
- Notes on Handling
- Maintenance/Inspection
- Warranty

Company Profile

- Company Profile
- Our Products
- History

Index

- Search by Alphabetical Order

Sales Offices

● Notes on Hydraulic Cylinder Speed Control Unit



Please pay attention to the cautions below. Design the hydraulic circuit for controlling the action speed of hydraulic cylinder. Improper circuit design may lead to malfunctions and damages. Please review the circuit design in advance.

● Flow Control Circuit for Single Acting Cylinder

For spring return single acting cylinders, restricting flow during release can extremely slow down or disrupt release action. The preferred method is to control the flow during the lock action using a valve that has free-flow in the release direction. It is also preferred to provide a flow control valve at each actuator.

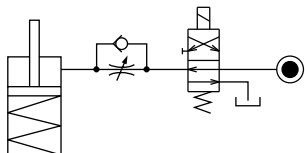

Accelerated clamping speed by excessive hydraulic flow to the cylinder may sustain damage. In this case add flow control to regulate flow. (Please add flow control to release flow if the lever weight is put on at the time of release action when using swing clamps.)

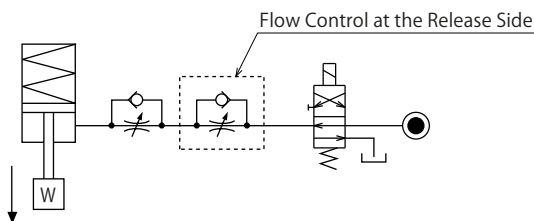

● Flow Control Circuit for Double Acting Cylinder

Flow control circuit for double acting cylinder should have meter-out circuits for both the lock and release sides. Meter-in control can have adverse effect by presence of air in the system.

However, in the case of controlling LKE, TMA, TLA, both lock side and release side should be meter-in circuit.

Refer to P.47 for speed adjustment of LKE.

For TMA and TLA, if meter-out circuit is used, abnormal high pressure is created, which causes oil leakage and damage.

【Meter-out Circuit】 (Except LKE/TMA/TLA)

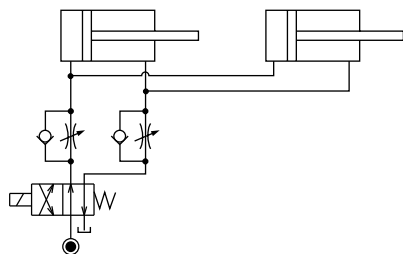

【Meter-in Circuit】 (LKE/TMA/TLA must be controlled with meter-in.)

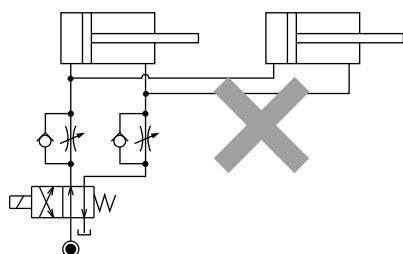

In the case of meter-out circuit, the hydraulic circuit should be designed with the following points.

- ① Single acting components should not be used in the same flow control circuit as the double acting components. The release action of the single acting cylinders may become erratic or very slow.

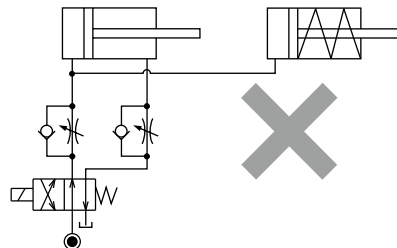

Refer to the following circuit when both the single acting cylinder and double acting cylinder are used together.

- Separate the control circuit.

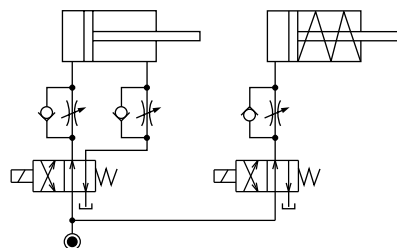

- Reduce the influence of double acting cylinder control unit. However, due to the back pressure in tank line, single action cylinder is activated after double action cylinder works.

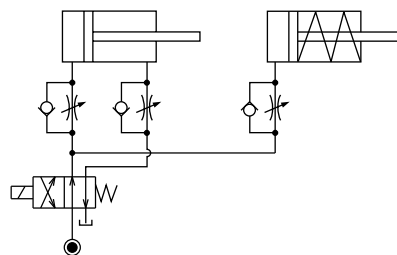

- ② In the case of meter-out circuit, the inner circuit pressure may increase during the cylinder action because of the fluid supply. The increase of the inner circuit pressure can be prevented by reducing the supplied fluid beforehand via the flow control valve. Especially when using sequence valve or pressure switches for clamping detection. If the back pressure is more than the set pressure then the system will not work as it is designed to.

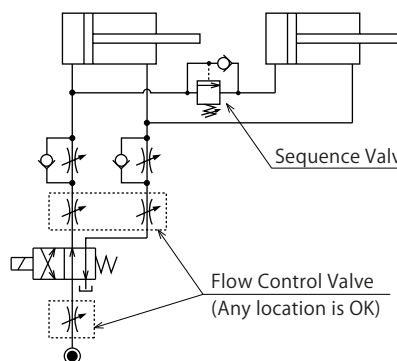

● Cautions

● Notes on Handling

- 1) It should be handled by qualified personnel.
 - The hydraulic machine and air compressor should be handled and maintained by qualified personnel.
- 2) Do not handle or remove the machine unless the safety protocols are ensured.
 - ① The machine and equipment can only be inspected or prepared when it is confirmed that the preventive devices are in place.
 - ② Before the machine is removed, make sure that the above-mentioned safety measures are in place. Shut off the air of hydraulic source and make sure no pressure exists in the hydraulic and air circuit.
 - ③ After stopping the machine, do not remove until the temperature cools down.
 - ④ Make sure there is no abnormality in the bolts and respective parts before restarting the machine or equipment.
- 3) Do not touch clamps (cylinder) while clamps (cylinder) is working. Otherwise, your hands may be injured due to clinching.

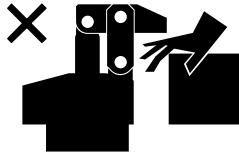

- 4) Do not disassemble or modify.
 - If the equipment is taken apart or modified, the warranty will be voided even within the warranty period.

● Maintenance and Inspection

- 1) Removal of the Machine and Shut-off of Pressure Source
 - Before the machine is removed, make sure that the above-mentioned safety measures are in place. Shut off the air of hydraulic source and make sure no pressure exists in the hydraulic and air circuit.
 - Make sure there is no abnormality in the bolts and respective parts before restarting.
- 2) Regularly clean the area around the piston rod and plunger.
 - If it is used when the surface is contaminated with dirt, it may lead to packing seal damage, malfunctioning, fluid leakage and air leaks.

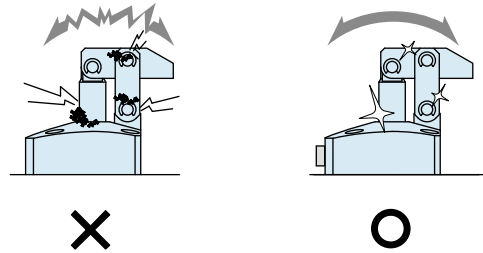

- 3) Please clean out the reference surface regularly (taper reference surface and seating surface) of locating machine. (VS/VT/VL/VM/VJ/VK/WVS/WM/WK/VX/VXF)
 - Location products, except VX/VXF model, can remove contaminants with cleaning functions. When installing pallets make sure there is no thick sludge like substances on pallets.
 - Continuous use with dirt on components will lead to locating functions not work properly, leaking and malfunction.

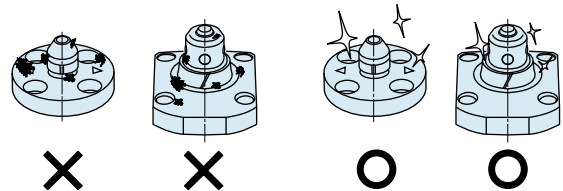

- 4) If disconnecting by couplers on a regular basis, air bleeding should be carried out daily to avoid air mixed in the circuit.
- 5) Regularly tighten nuts, bolts, pins, cylinders and pipe line to ensure proper use.
- 6) Make sure the hydraulic fluid has not deteriorated.
- 7) Make sure there is smooth action and no abnormal noise.
 - Especially when it is restarted after left unused for a long period, make sure it can be operated correctly.
- 8) The products should be stored in the cool and dark place without direct sunshine or moisture.
- 9) Please contact us for overhaul and repair.

● Warranty

1) Warranty Period

- The product warranty period is 18 months from shipment from our factory or 12 months from initial use, whichever is earlier.

2) Warranty Scope

- If the product is damaged or malfunctions during the warranty period due to faulty design, materials or workmanship, we will replace or repair the defective part at our expense.

Defects or failures caused by the following are not covered.

- ① If the stipulated maintenance and inspection are not carried out.
- ② If the product is used while it is not suitable for use based on the operator' s judgment, resulting in defect.
- ③ If it is used or handled in inappropriate way by the operator.
(Including damage caused by the misconduct of the third party.)
- ④ If the defect is caused by reasons other than our responsibility.
- ⑤ If repair or modifications are carried out by anyone other than Kosmek, or without our approval and confirmation, it will void warranty.
- ⑥ Other caused by natural disasters or calamities not attributable to our company.
- ⑦ Parts or replacement expenses due to parts consumption and deterioration.
(Such as rubber, plastic, seal material and some electric components.)

Damages excluding from direct result of a product defect shall be excluded from the warranty.

High-Power
Series

Pneumatic Series

Hydraulic Series

Valve / Coupler
Hydraulic Unit

Manual Operation
Accessories

Cautions / Others

Cautions

Installation Notes
(For Hydraulic Series)

Hydraulic Fluid List

Notes on Hydraulic Cylinder
Speed Control Circuit

Notes on Handling

Maintenance/
Inspection

Warranty

Company Profile

Company Profile

Our Products

History

Index

Search by
Alphabetical Order

Sales Offices

Control Valve

Model BZL

Model BZT

Model BZX

Model JZG



Directly mounted to clamps, flow control valve • Air bleeding • plug

- Directly mounted to clamps

Flow control valve, air bleeding valve, G-thread plug for G-thread (-C option) directly mounted.

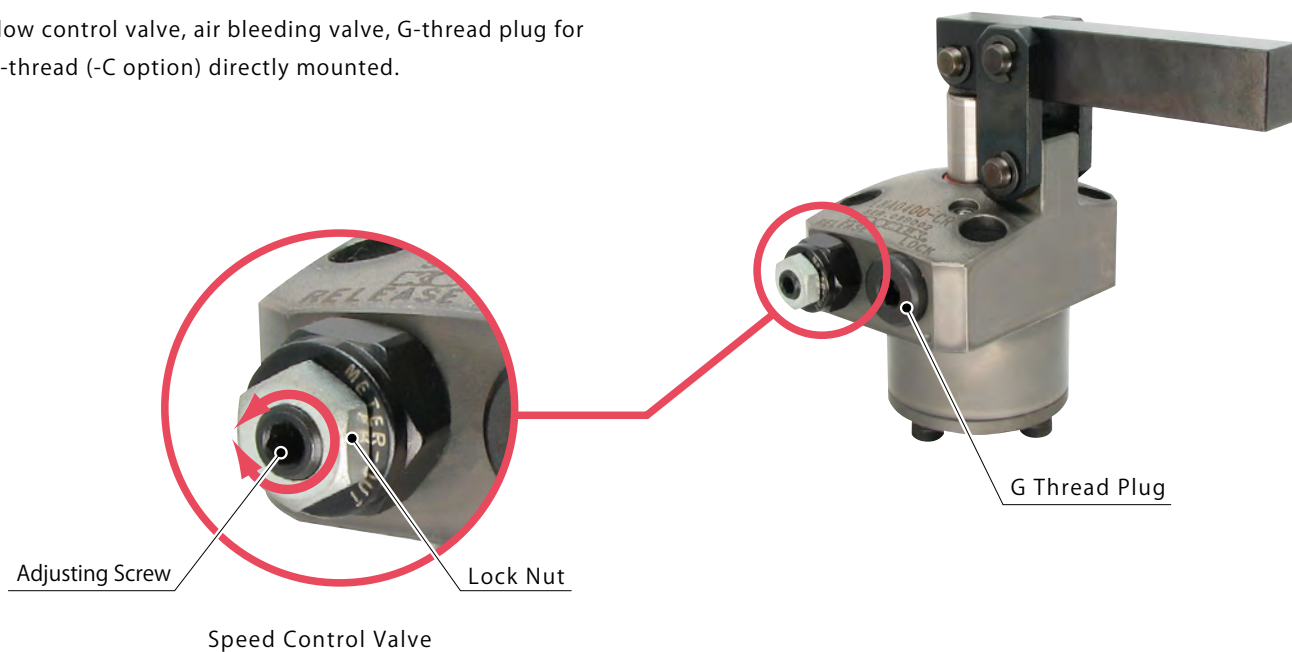

Speed Control Valve

Model BZL

Model BZT







Air Bleed Valve

Model BZX

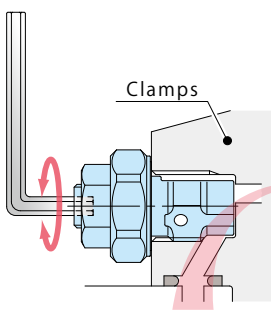
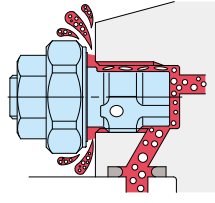

G Thread Plug

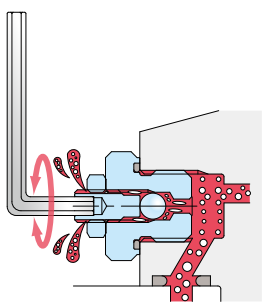
Model JZG

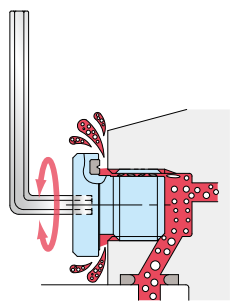
	Operating Pressure Range	Action Description
<p>Speed Control Valve (For Low Pressure)</p> <p>Model BZL → P.729</p> 	7MPa or less	<p>Adjust the flow by wrench. It can adjust the clamping action speed individually.</p>  <p>Clamps</p> <p>Flow Control</p>
<p>Speed Control Valve (For High Pressure)</p> <p>Model BZT → P.733</p>	35MPa or less	<p>Air bleeding in the circuit is possible by loosening flow control valve.</p> 
<p>Air Bleed Valve</p> <p>Model BZX → P.735</p> 	25MPa or less	<p>Air bleeding in the circuit is possible by wrench.</p> 
<p>G Thread Plug</p> <p>Model JZG → P.737</p> 	35MPa or less	<p>Air bleeding in the circuit is possible by loosening G thread plug.</p> 

High-Power Series

Pneumatic Series

Hydraulic Series

Valve / Coupler Hydraulic Unit

Manual Operation Accessories

Cautions / Others

Hole Clamp

- SFA
- SFC

Swing Clamp

- LHA
- LHC
- LHS
- LHW
- LT/LG
- TLA-2
- TLB-2
- TLA-1

Link Clamp

- LKA
- LKC
- LKW
- LM/LJ
- TMA-2
- TMA-1

Work Support

- LD
- LC
- TNC
- TC

Air Sensing Lift Cylinder

- LLW

Compact Cylinder

- LL
- LLR
- LLU
- DP
- DR
- DS
- DT

Block Cylinder

- DBA
- DBC

Control Valve

- BZL**
- BZT**
- BZX/JZG**

Pallet Clamp

- VS
- VT

Expansion Locating Pin

- VL
- VM
- VJ
- VK

Pull Stud Clamp

- FP
- FQ

Customized Spring Cylinder

- DWA/DWB

Model No. Indication (Speed Control Valve for Low Pressure)

BZL 0 10 0 - B

1 2 3



1 G Thread Size

- 10** : Thread Part G1/8A Thread
- 20** : Thread Part G1/4A Thread
- 30** : Thread Part G3/8A Thread

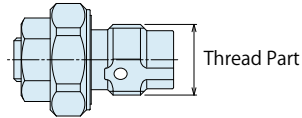

2 Design No.

- 0** : Revision Number

3 Control Method

- A** : Meter-in
- B** : Meter-out

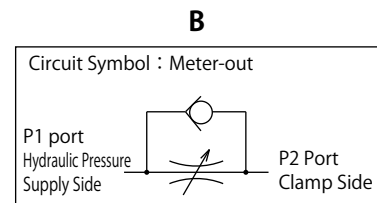
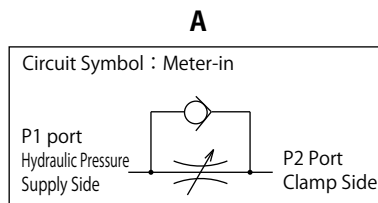

Specifications

Model No.	BZL0100-A	BZL0200-A	BZL0300-A	BZL0100-B	BZL0200-B	BZL0300-B
Max. Operating Pressure MPa	7					
Withstanding Pressure MPa	10.5					
Control Method	Meter-in			Meter-out		
G Thread Size	G1/8A	G1/4A	G3/8A	G1/8A	G1/4A	G3/8A
Cracking Pressure MPa	0.04			0.12		
Max. Passage Area mm ²	2.6	5.0	11.6	2.6	5.0	10.2
Usable Fluid	General Hydraulic Oil Equivalent to ISO-VG-32					
Operating Temperature °C	0 ~ 70					
Tightening Torque for Main Body N·m	10	25	35	10	25	35

- Notes
1. Minimum passage area when fully opened is the same as the maximum passage area in the table above.
 2. It must be mounted with recommended torque. Because of the structure of the metal seal, if mounting torque is insufficient, the flow control valve may not be able to adjust the flow rate.
 3. Don't use used BZL to other clamps.
Flow control will not be made because the bottom depth difference of G thread makes metal seal insufficient.

Applicable Products

Model No.	DBA (Single Action) Block Cylinder	DBC (Single Action) Block Cylinder	LC (Single Action) Work Support	LHA (Double Action) Swing Clamp	LHC (Double Action) Swing Clamp	LHE (Double Action) High-Power Swing Clamp	LHS (Double Action) Swing Clamp	LHW (Double Action) Swing Clamp
BZL0100-A	(DBA0250-C□) (DBA0320-C□)	(DBC0250-C□) (DBC0320-C□)	LC0402-C□□□ LC0482-C□□□ LC0552-C□□□ LC0652-C□□□	(LHA0360-C□□□) (LHA0400-C□□□) (LHA0480-C□□□) (LHA0550-C□□□)	(LHC0360-C□□□) (LHC0400-C□□□) (LHC0480-C□□□) (LHC0550-C□□□)	/	(LHS0360-C□□□) (LHS0400-C□□□) (LHS0480-C□□□) (LHS0550-C□□□)	(LHW0400-C□□□) (LHW0480-C□□□) (LHW0550-C□□□)
BZL0100-B	DBA0250-C□ DBA0320-C□	DBC0250-C□ DBC0320-C□	/	LHA0360-C□□□ LHA0400-C□□□ LHA0480-C□□□ LHA0550-C□□□	LHC0360-C□□□ LHC0400-C□□□ LHC0480-C□□□ LHC0550-C□□□	LHE0300-C□ LHE0360-C□ LHE0400-C□ LHE0480-C□ LHE0550-C□	LHS0360-C□□□ LHS0400-C□□□ LHS0480-C□□□ LHS0550-C□□□	LHW0400-C□□□ LHW0480-C□□□ LHW0550-C□□□
BZL0200-A	(DBA0400-C□) (DBA0500-C□)	(DBC0400-C□) (DBC0500-C□)	LC0752-C□□□ LC0902-C□□□	(LHA0650-C□□□) (LHA0750-C□□□)	(LHC0650-C□□□)	/	(LHS0650-C□□□) (LHS0750-C□□□)	(LHW0650-C□□□)
BZL0200-B	DBA0400-C□ DBA0500-C□	DBC0400-C□ DBC0500-C□	/	LHA0650-C□□□ LHA0750-C□□□	LHC0650-C□□□	/	LHS0650-C□□□ LHS0750-C□□□	LHW0650-C□□□
BZL0300-A	/	/	/	(LHA0900-C□□□) (LHA1050-C□□□)	/	/	(LHS0900-C□□□) (LHS1050-C□□□)	/
BZL0300-B	/	/	/	LHA0900-C□□□ LHA1050-C□□□	/	/	LHS0900-C□□□ LHS1050-C□□□	/

Model No.	LT/LG (Single Action) Swing Clamp	LKA (Double Action) Link Clamp	LKC (Double Action) Link Clamp	LKE (Double Action) High-Power Link Clamp	LKW (Double Action) Link Clamp	LM/LJ (Single Action) Link Clamp	LL (Double Action) Linear Cylinder	LLR (Double Action) Linear Cylinder
BZL0100-A	LT0360-C□ LT0400-C□ LT0480-C□ LT0550-C□	(LKA0360-C□□□) (LKA0400-C□□□) (LKA0480-C□□□) (LKA0550-C□□□)	(LKC0400-C□□□) (LKC0480-C□□□) (LKC0550-C□□□)	LKE0300-C□ LKE0360-C□ LKE0400-C□ LKE0480-C□ LKE0550-C□	(LKW0400-C□□□) (LKW0480-C□□□) (LKW0550-C□□□)	LM0360-C□ LM0400-C□ LM0480-C□ LM0550-C□	(LL0360-C□□□) (LL0400-C□□□) (LL0480-C□□□) (LL0550-C□□□)	(LLR0360-C□□□□) (LLR0400-C□□□□) (LLR0480-C□□□□) (LLR0550-C□□□□)
BZL0100-B	/	LKA0360-C□□□ LKA0400-C□□□ LKA0480-C□□□ LKA0550-C□□□	LKC0400-C□□□ LKC0480-C□□□ LKC0550-C□□□	/	LKW0400-C□□□ LKW0480-C□□□ LKW0550-C□□□	/	LL0360-C□□□ LL0400-C□□□ LL0480-C□□□ LL0550-C□□□	LLR0360-C□□□□ LLR0400-C□□□□ LLR0480-C□□□□ LLR0550-C□□□□
BZL0200-A	LT0650-C□ LT0750-C□	(LKA0650-C□□□) (LKA0750-C□□□)	(LKC0650-C□□□)	/	(LKW0650-C□□□)	LM0650-C□ LM0750-C□	(LL0650-C□□□) (LL0750-C□□□)	(LLR0650-C□□□□) (LLR0750-C□□□□)
BZL0200-B	/	LKA0650-C□□□ LKA0750-C□□□	LKC0650-C□□□	/	LKW0650-C□□□	/	LL0650-C□□□ LL0750-C□□□	LLR0650-C□□□□ LLR0750-C□□□□
BZL0300-A	LG0900-C□ LG1050-C□	(LKA0900-C□□□) (LKA1050-C□□□)	/	/	/	LJ0902-C□ LJ1052-C□	(LL0900-C□□□) (LL1050-C□□□)	(LLR0900-C□□□□) (LLR1050-C□□□□)
BZL0300-B	/	LKA0900-C□□□ LKA1050-C□□□	/	/	/	/	LL0900-C□□□ LL1050-C□□□	LLR0900-C□□□□ LLR1050-C□□□□

Model No.	LLW (Double Action) Lift Cylinder
BZL0100-A	(LLW0360-C□□□) (LLW0400-C□□□) (LLW0480-C□□□)
BZL0100-B	LLW0360-C□□□ LLW0400-C□□□ LLW0480-C□□□

- Note 1. Flow control circuit for double acting cylinder both should have meter-out circuits for the locking side and release side except model LKE/TLA/TMA.
Meter-in controls can be adversely affected by any air in the system.

High-Power Series

Pneumatic Series

Hydraulic Series

Valve / Coupler Hydraulic Unit

Manual Operation Accessories

Cautions / Others

Hole Clamp

SFA
SFC

Swing Clamp

LHA
LHC
LHS
LHW
LT/LG
TLA-2
TLB-2
TLA-1

Link Clamp

LKA
LKC
LKW
LM/LJ
TMA-2
TMA-1

Work Support

LD
LC
TNC
TC

Air Sensing Lift Cylinder

LLW

Compact Cylinder

LL
LLR
LLU
DP
DR
DS
DT

Block Cylinder

DBA
DBC

Control Valve

BZL
BZT
BZX/JZG

Pallet Clamp

VS
VT

Expansion Locating Pin

VL
VM
VJ
VK

Pull Stud Clamp

FP
FQ

Customized Spring Cylinder

DWA/DWB

● Flow Rate Graph < Hydraulic Fluids ISO-VG32 (25~35°C) >

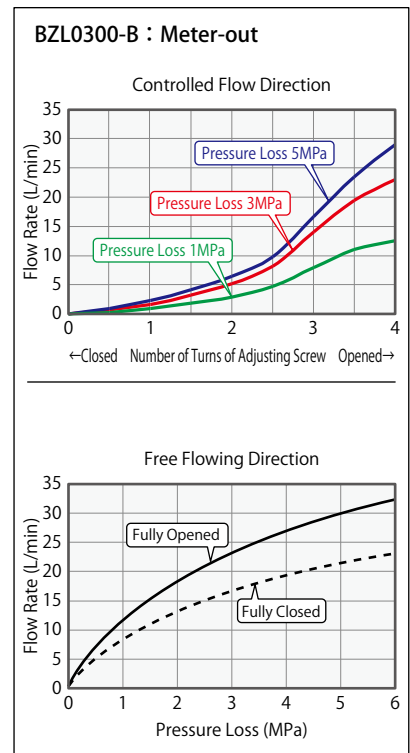
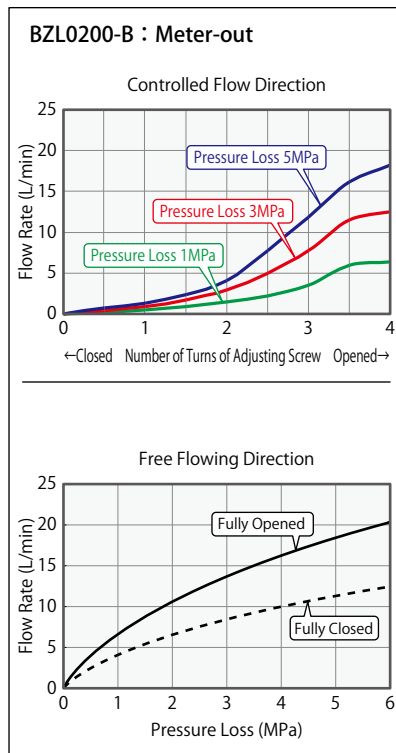
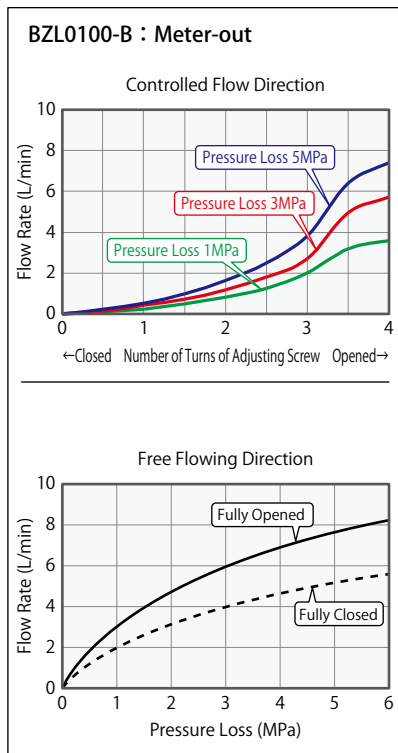
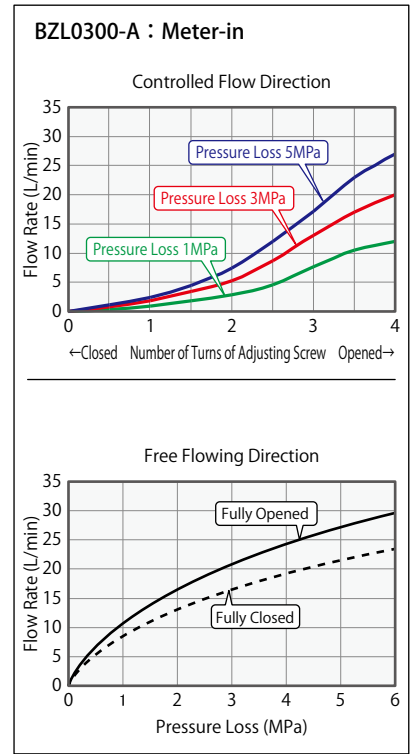
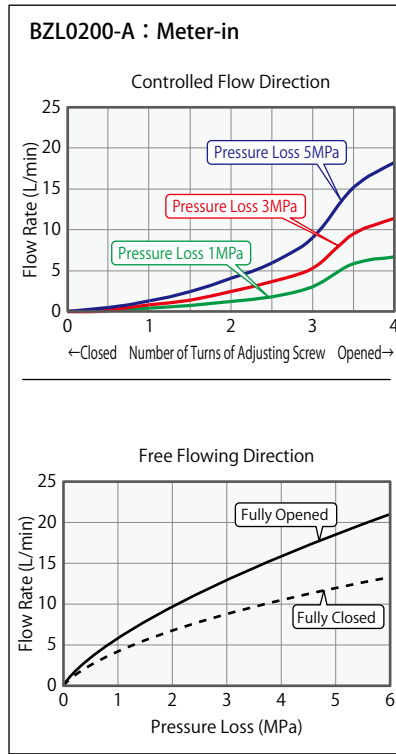
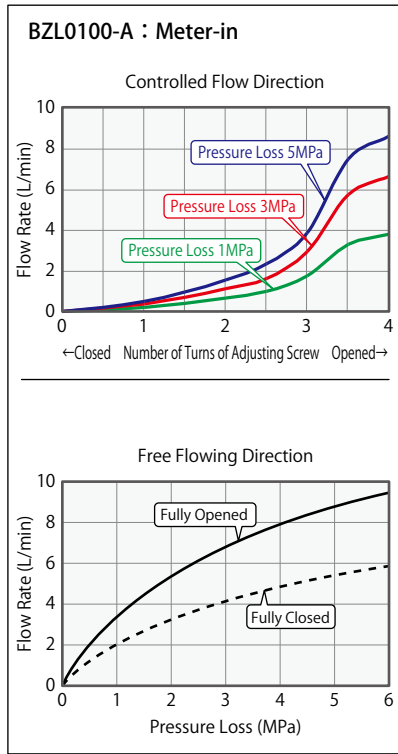

External Dimensions

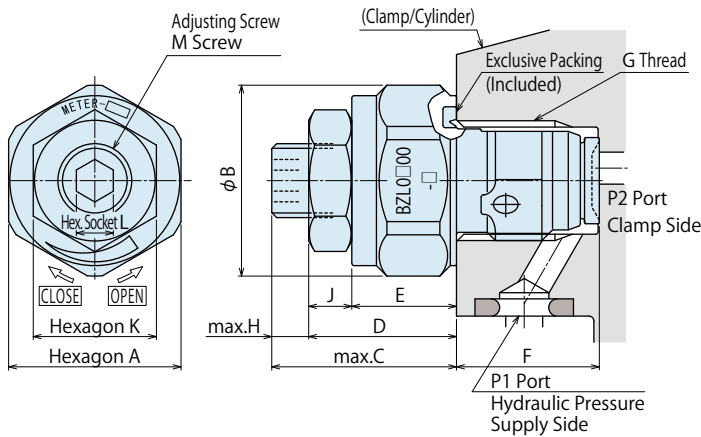

Machining Dimensions of Mounting Area

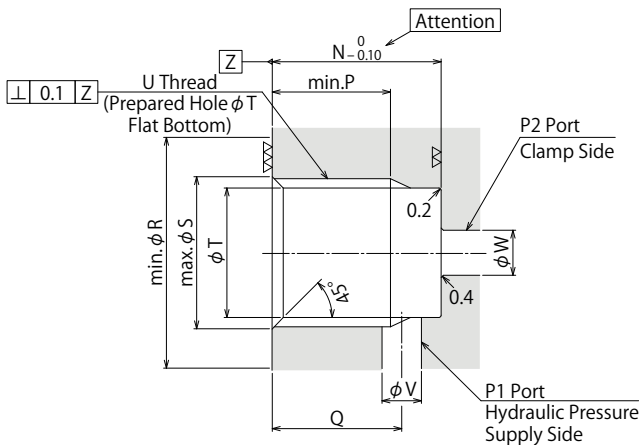

Notes

1. Since the $\nabla\nabla$ area is sealing part, be careful not to damage it.
2. Since the $\nabla\nabla$ area is the metal sealing part of BZL, be careful not to damage it. (Especially when deburring)
3. No cutting chips or burr should be at the tolerance part of machining hole.
4. As shown in the drawing, P1 port is used as the hydraulic supply and P2 port as the clamp side.
5. If mounting plugs or fittings with G thread specification available in the market, the dimension '※1' should be 12.5.

Notes

1. Please read "Notes on Hydraulic Cylinder Speed Control Circuit" to assist with proper hydraulic circuit design.
If there is something wrong with the circuit design, it leads to the applications malfunction and damage. (Refer to P.1044)
2. It is dangerous to air bleed during operation under high pressure. It must be done under lower pressure.
(For reference: the minimum operating range of the product within the circuit.)

(mm)

Model No.	BZL0100-□	BZL0200-□	BZL0300-□
A	14	18	22
B	15.5	20	24
C	15	16	19
D	12	13	16
E	8.5	9.5	11
F	(11.6)	(15.1)	(17.6)
G	G1/8	G1/4	G3/8
H	3	3	3
J	3.5	3.5	5
K	10	10	13
L	3	3	4
M	M6×0.75	M6×0.75	M8×0.75
N	11.5	15	17.5
P	8.5	11※1	13
Q	9	11.5	13
R (Flat Surface Area)	16	20.5	24.5
S	10	13.5	17
T	8.7	11.5	15
U	G1/8	G1/4	G3/8
V	2 ~ 3	3 ~ 4	4 ~ 5
W	2.5 ~ 5	3.5 ~ 7	4.5 ~ 9

High-Power Series

Pneumatic Series

Hydraulic Series

Valve / Coupler Hydraulic Unit

Manual Operation Accessories

Cautions / Others

Hole Clamp

SFA
SFC

Swing Clamp

LHA
LHC
LHS
LHW
LT/LG
TLA-2
TLB-2
TLA-1

Link Clamp

LKA
LKC
LKW
LM/LJ
TMA-2
TMA-1

Work Support

LD
LC
TNC
TC

Air Sensing Lift Cylinder

LLW

Compact Cylinder

LL
LLR
LLU
DP
DR
DS
DT

Block Cylinder

DBA
DBC

Control Valve

BZL
BZT
BZX/JZG

Pallet Clamp

VS
VT

Expansion Locating Pin

VL
VM
VJ
VK

Pull Stud Clamp

FP
FQ

Customized Spring Cylinder

DWA/DWB

Model No. Indication (Air Bleed Valve)

BZX0 1 0

1 2



1 G Thread Size

- 1 : Thread Part G1/8A Thread
- 2 : Thread Part G1/4A Thread
- 3 : Thread Part G3/8A Thread

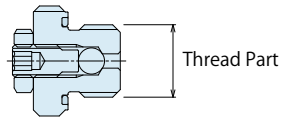

2 Design No.

- 0 : Revision Number

Specifications

Model No.	BZX010	BZX020	BZX030
Max. Operating Pressure MPa	25		
Withstanding Pressure MPa	37.5		
G Thread Size	G1/8A	G1/4A	G3/8A
Usable Fluid	General Hydraulic Oil Equivalent to ISO-VG-32		
Operating Temperature °C	0 ~ 70		
Tightening Torque for Main Body N·m	10	25	35

Circuit Symbol

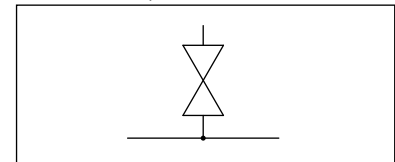

- Notes
- Do not over loosen the plug during air venting.
(Do not loosen for more than 2 turns from the fully closed position.)
 - It is dangerous to have air venting operation under high pressure. It must be done under lower pressure.
(For reference: the minimum operation pressure range of the product within the circuit)
 - Refer to the processing dimensions for BZL mounting area.

Applicable Products

Model No.	DBA (Single Action) Block Cylinder	DBC (Single Action) Block Cylinder	LC (Single Action) Work Support	LHA (Double Action) Swing Clamp	LHC (Double Action) Swing Clamp	LHE (Double Action) High-Power Swing Clamp	LHS (Double Action) Swing Clamp	LHW (Double Action) Swing Clamp
BZX010	DBA0250-C□ DBA0320-C□	DBC0250-C□ DBC0320-C□	LC0402-C□□□ LC0482-C□□□ LC0552-C□□□ LC0652-C□□□	LHA0360-C□□□ LHA0400-C□□□ LHA0480-C□□□ LHA0550-C□□□	LHC0360-C□□□ LHC0400-C□□□ LHC0480-C□□□ LHC0550-C□□□	LHE0300-C□ LHE0360-C□ LHE0400-C□ LHE0480-C□ LHE0550-C□	LHS0360-C□□□ LHS0400-C□□□ LHS0480-C□□□ LHS0550-C□□□	LHW0400-C□□□ LHW0480-C□□□ LHW0550-C□□□
BZX020	DBA0400-C□ DBA0500-C□	DBC0400-C□ DBC0500-C□	LC0752-C□□□ LC0902-C□□□	LHA0650-C□□□ LHA0750-C□□□	LHC0650-C□□□		LHS0650-C□□□ LHS0750-C□□□	LHW0650-C□□□
BZX030				LHA0900-C□□□ LHA1050-C□□□			LHS0900-C□□□ LHS1050-C□□□	

Model No.	LT/LG (Single Action) Swing Clamp	LKA (Double Action) Link Clamp	LKC (Double Action) Link Clamp	LKE (Double Action) High-Power Link Clamp	LKW (Double Action) Link Clamp	LM/LJ (Single Action) Link Clamp	LL (Double Action) Linear Cylinder	LLR (Double Action) Linear Cylinder
BZX010	LT0360-C□ LT0400-C□ LT0480-C□ LT0550-C□	LKA0360-C□□□ LKA0400-C□□□ LKA0480-C□□□ LKA0550-C□□□	LKC0400-C□□□ LKC0480-C□□□ LKC0550-C□□□	LKE0300-C□ LKE0360-C□ LKE0400-C□ LKE0480-C□ LKE0550-C□	LKW0400-C□□□ LKW0480-C□□□ LKW0550-C□□□	LM0360-C□ LM0400-C□ LM0480-C□ LM0550-C□	LL0360-C□□□ LL0400-C□□□ LL0480-C□□□ LL0550-C□□□	LLR0360-C□□□□ LLR0400-C□□□□ LLR0480-C□□□□ LLR0550-C□□□□
BZX020	LT0650-C□ LT0750-C□	LKA0650-C□□□ LKA0750-C□□□	LKC0650-C□□□		LKW0650-C□□□	LM0650-C□ LM0750-C□	LL0650-C□□□ LL0750-C□□□	LLR0650-C□□□□ LLR0750-C□□□□
BZX030	LG0900-C□ LG1050-C□	LKA0900-C□□□ LKA1050-C□□□				LJ0902-C□ LJ1052-C□	LL0900-C□□□ LL1050-C□□□	LLR0900-C□□□□ LLR1050-C□□□□

Model No.	LLW (Double Action) Lift Cylinder
BZX010	LLW0360-C□□□ LLW0400-C□□□ LLW0480-C□□□

External Dimensions

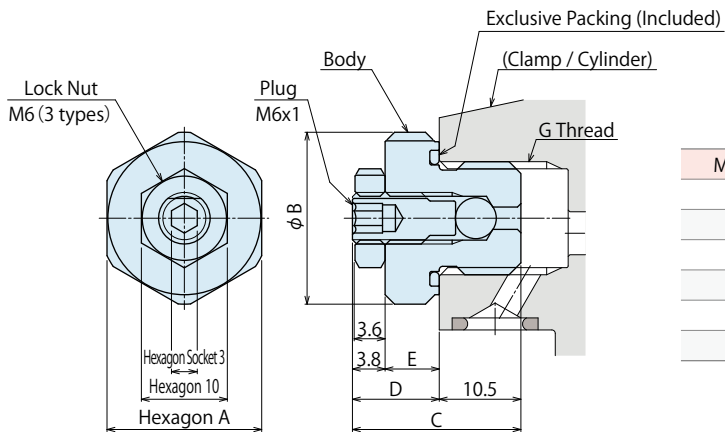

Model No.	BZX010	BZX020	BZX030
A	14	18	22
B	15.5	20	24
C	19.8	20.6	20.6
D	9.3	10.1	10.1
E	5.5	6.3	6.3
G	G1/8	G1/4	G3/8

(mm)

High-Power
Series

Pneumatic Series

Hydraulic Series

Valve / Coupler
Hydraulic UnitManual Operation
Accessories

Cautions / Others

Hole Clamp

SFA
SFC

Swing Clamp

LHA
LHC
LHS
LHW
LT/LG
TLA-2
TLB-2
TLA-1

Link Clamp

LKA
LKC
LKW
LM/LJ
TMA-2
TMA-1

Work Support

LD
LC
TNC
TCAir Sensing
Lift Cylinder

LLW

Compact Cylinder

LL
LLR
LLU
DP
DR
DS
DT

Block Cylinder

DBA
DBC

Control Valve

BZL
BZT

BZX/JZG

Pallet Clamp

VS
VTExpansion
Locating PinVL
VM
VJ
VK

Pull Stud Clamp

FP
FQCustomized
Spring Cylinder

DWA/DWB

Model No. Indication (G Thread Plug with Air Bleeding Function)

JZG0 1 0

1 2



1 G Thread Size

- 1 : Thread Part G1/8A Thread
- 2 : Thread Part G1/4A Thread
- 3 : Thread Part G3/8A Thread

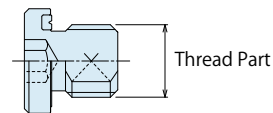

2 Design No.

- 0 : Revision Number

Specifications

Model No.	JZG010	JZG020	JZG030
Max. Operating Pressure MPa	35		
Withstanding Pressure MPa	42		
G Thread Size	G1/8A	G1/4A	G3/8A
Usable Fluid	General Hydraulic Oil Equivalent to ISO-VG-32		
Operating Temperature °C	0 ~ 70		
Tightening Torque for Main Body N·m	10	25	35

- Notes
- It is dangerous to have air venting operation under high pressure. It must be done under lower pressure.
(For reference: the minimum operation pressure range of the product within the circuit)
 - Refer to the processing dimensions for BZL mounting area.

Applicable Products

Model No.	DBA (Single Action) Block Cylinder	DBC (Single Action) Block Cylinder	LC (Single Action) Work Support	LHA (Double Action) Swing Clamp	LHC (Double Action) Swing Clamp	LHE (Double Action) High-Power Swing Clamp	LHS (Double Action) Swing Clamp	LHW (Double Action) Swing Clamp
JZG010	DBA0250-C□ DBA0320-C□	DBC0250-C□ DBC0320-C□	LC0402-C□□□ LC0482-C□□□ LC0552-C□□□ LC0652-C□□□	LHA0360-C□□□ LHA0400-C□□□ LHA0480-C□□□ LHA0550-C□□□	LHC0360-C□□□ LHC0400-C□□□ LHC0480-C□□□ LHC0550-C□□□	LHE0300-C□ LHE0360-C□ LHE0400-C□ LHE0480-C□ LHE0550-C□	LHS0360-C□□□ LHS0400-C□□□ LHS0480-C□□□ LHS0550-C□□□	LHW0400-C□□□ LHW0480-C□□□ LHW0550-C□□□
JZG020	DBA0400-C□ DBA0500-C□	DBC0400-C□ DBC0500-C□	LC0752-C□□□ LC0902-C□□□	LHA0650-C□□□ LHA0750-C□□□	LHC0650-C□□□		LHS0650-C□□□ LHS0750-C□□□	LHW0650-C□□□
JZG030				LHA0900-C□□□ LHA1050-C□□□			LHS0900-C□□□ LHS1050-C□□□	

Model No.	LT/LG (Single Action) Swing Clamp	LKA (Double Action) Link Clamp	LKC (Double Action) Link Clamp	LKE (Double Action) High-Power Link Clamp	LKW (Double Action) Link Clamp	LM/LJ (Single Action) Link Clamp	LL (Double Action) Linear Cylinder	LLR (Double Action) Linear Cylinder
JZG010	LT0360-C□ LT0400-C□ LT0480-C□ LT0550-C□	LKA0360-C□□□ LKA0400-C□□□ LKA0480-C□□□ LKA0550-C□□□	LKC0400-C□□□ LKC0480-C□□□ LKC0550-C□□□	LKE0300-C□ LKE0360-C□ LKE0400-C□ LKE0480-C□ LKE0550-C□	LKW0400-C□□□ LKW0480-C□□□ LKW0550-C□□□	LM0360-C□ LM0400-C□ LM0480-C□ LM0550-C□	LL0360-C□□□ LL0400-C□□□ LL0480-C□□□ LL0550-C□□□	LLR0360-C□□□□□ LLR0400-C□□□□□ LLR0480-C□□□□□ LLR0550-C□□□□□
JZG020	LT0650-C□ LT0750-C□	LKA0650-C□□□ LKA0750-C□□□	LKC0650-C□□□		LKW0650-C□□□	LM0650-C□ LM0750-C□	LL0650-C□□□ LL0750-C□□□	LLR0650-C□□□□□ LLR0750-C□□□□□
JZG030	LG0900-C□ LG1050-C□	LKA0900-C□□□ LKA1050-C□□□				LJ0902-C□ LJ1052-C□	LL0900-C□□□ LL1050-C□□□	LLR0900-C□□□□□ LLR1050-C□□□□□

Model No.	LLW (Double Action) Lift Cylinder	TLA-2 (Double Action) Swing Clamp	TLB-2 (Double Action) Swing Clamp	TLA-1 (Single Action) Swing Clamp	TMA-2 (Double Action) Link Clamp	TMA-1 (Single Action) Link Clamp
JZG010	LLW0360-C□□□□□ LLW0400-C□□□□□ LLW0480-C□□□□□	TLA0401-2C□□□ TLA0601-2C□□□ TLA0801-2C□□□ TLA1001-2C□□□ TLA1601-2C□□□	TLB0401-2C□□□ TLB0601-2C□□□ TLB0801-2C□□□ TLB1001-2C□□□ TLB1601-2C□□□	TLA0402-1C□ TLA0602-1C□ TLA0802-1C□ TLA1002-1C□ TLA1602-1C□	TMA0250-2C□ TMA0400-2C□ TMA0600-2C□ TMA1000-2C□	TMA0250-1C□ TMA0400-1C□ TMA0600-1C□ TMA1000-1C□
JZG020		TLA2001-2C□□□ TLA2501-2C□□□ TLA4001-2C□□□	TLB2001-2C□□□ TLB2501-2C□□□ TLB4001-2C□□□	TLA2002-1C□ TLA2502-1C□ TLA4002-1C□	TMA1600-2C□ TMA2500-2C□ TMA3200-2C□	TMA1600-1C□ TMA2500-1C□ TMA3200-1C□

External Dimensions

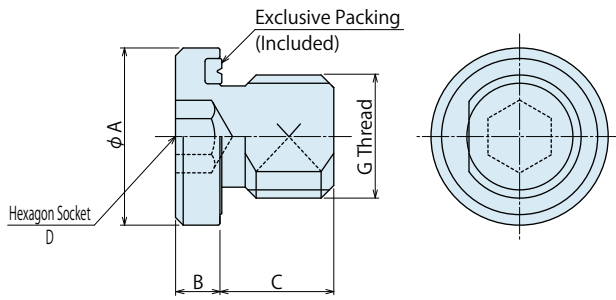

Model No.	JZG010	JZG020	JZG030
A	14	18	22
B	3.5	4.5	4.5
C	8	9	10
D	5	6	8
G	G1/8A	G1/4A	G3/8A

(mm)

High-Power
Series

Pneumatic Series

Hydraulic Series

Valve / Coupler
Hydraulic UnitManual Operation
Accessories

Cautions / Others

Hole Clamp

SFA
SFC

Swing Clamp

LHA
LHC
LHS
LHW
LT/LG
TLA-2
TLB-2
TLA-1

Link Clamp

LKA
LKC
LKW
LM/LJ
TMA-2
TMA-1

Work Support

LD
LC
TNC
TCAir Sensing
Lift Cylinder

LLW

Compact Cylinder

LL
LLR
LLU
DP
DR
DS
DT

Block Cylinder

DBA
DBC

Control Valve

BZL
BZT**BZX/JZG**

Pallet Clamp

VS
VTExpansion
Locating PinVL
VM
VJ
VK

Pull Stud Clamp

FP
FQCustomized
Spring Cylinder

DWA/DWB

Manifold Block

Model WHZ-MD

Model LZY-MD

Model LZ-MS

Model LZ-MP

Model TMZ-1MB

Model TMZ-2MB

Model DZ-MG

Model DZ-MS

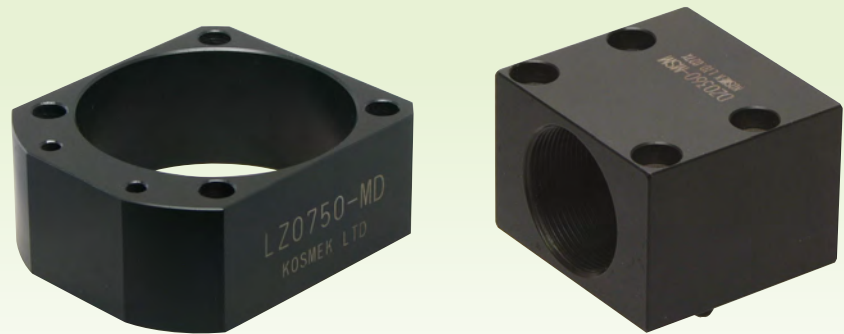

- **Manifold Block**

The mounting height of clamp is adjustable with the manifold block.

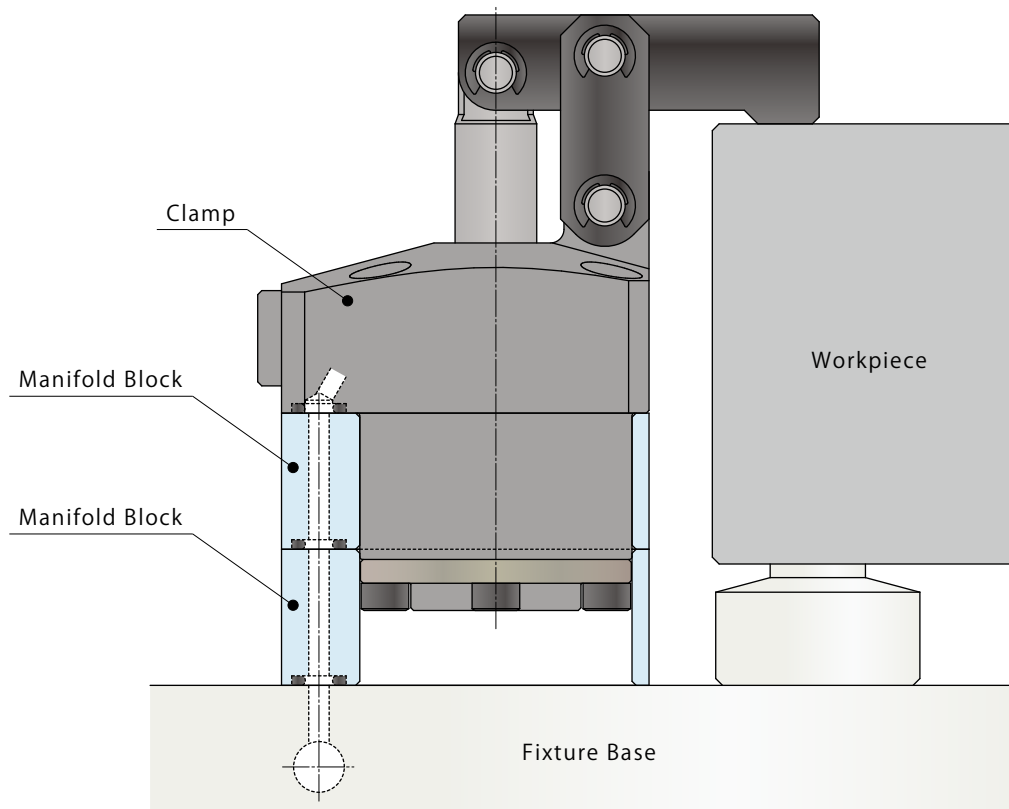

Applicable Model

Manifold Block Model No.	Corresponding Item Model No.
Model WHZ-MD	Model WCA Model WHA Model WCE Model WHE
Model LZY-MD	Model LKA Model LKE Model LHC Model LHS Model LKC Model LHA Model LHE Model LL
Model LZ-MS	Model LM Model LT Model LJ Model LG
Model LZ-MP	Model LC Model TC
Model TMZ-1MB	Model TMA-1
Model TMZ-2MB	Model TMA-2
Model DZ-MG□/MS□	Model DP

- High-Power Series
- Pneumatic Series
- Hydraulic Series
- Valve / Coupler Hydraulic Unit
- Manual Operation Accessories**
- Cautions / Others

- Screw Locator
- VXF

- Manual Expansion Locating Pin
- VX

- Manifold Block**
- WHZ-MD
- LZY-MD
- LZ-MS
- LZ-MP
- TMZ-1MB
- TMZ-2MB
- DZ-M

- Manifold Block / Nut
- DZ-R
- DZ-C
- DZ-P
- DZ-B
- LZ-S
- LZ-SQ
- TNZ-S
- TNZ-SQ

- Pressure Switch
- JB

- Pressure Gauge
- JGA/JGB

- Manifold
- JX

- Coupler Switch
- PS

- G-Thread Fitting

Application Examples

• Work Support (LC) Application Example

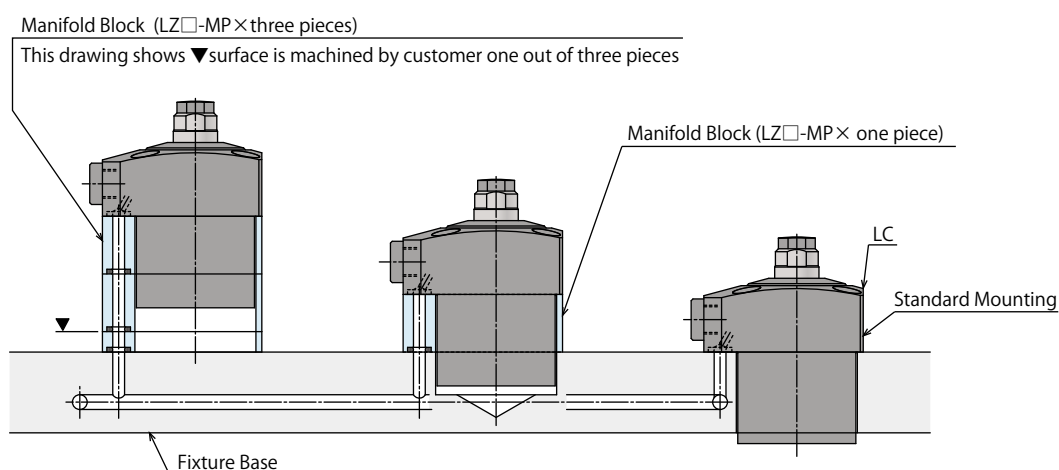

• Push Cylinder (DP) Application Example

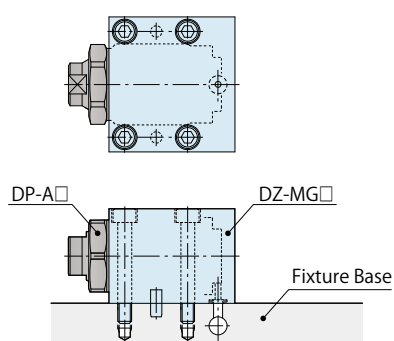

Manifold Block for WCA/WCE/WHA/WHE

Model No. Indication

WHZ 048 0 - MD

Size
(Refer to following table)

Design No.
(Revision Number)

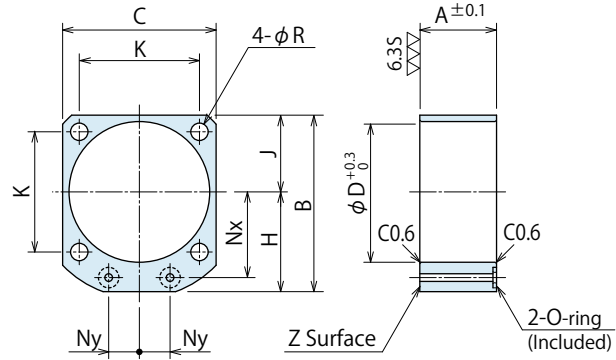

(mm)

Model No.	WHZ0600-MD	WHZ0320-MD	WHZ0400-MD	WHZ0500-MD	WHZ0630-MD
Corresponding Item	WCE0601	WCA0321 WCE1001	WCA0401 WCE1601	WCA0501 WCE2501	WCA0631 WCE4001
Model Number	WHE0600	WHA0320 WHE1000	WHA0400 WHE1600	WHA0500 WHE2500	WHA0630 WHE4000
A	23	25	27	31	35
B	54	60	67	77	88.5
C	45	50	58	68	81
D	40	46	54	64	77
H	31.5	35	38	43	48
J	22.5	25	29	34	40.5
K	34	39	45	53	65
Nx	26	28	31	36	41
Ny	9	10	13	15	20
R	5.5	5.5	5.5	6.5	6.5
O-ring	1BP5	1BP7	1BP7	1BP7	1BP7
Mass kg	0.1	0.1	0.1	0.2	0.2

- Notes
1. Material: A2017BE-T4
 2. Mounting bolts are not provided. Prepare mounting bolts according to the mounting height using the A dimensions as a reference.
 3. If thickness other than A is required, perform additional machining on surface Z. Please refer to the drawing.

Manifold Block for LKA/LKC/LKE/LHA/LHC/LHE/LHS/LL

Model No. Indication

LZY 048 0 - MD

Size
(Refer to following table)

Design No.
(Revision Number)

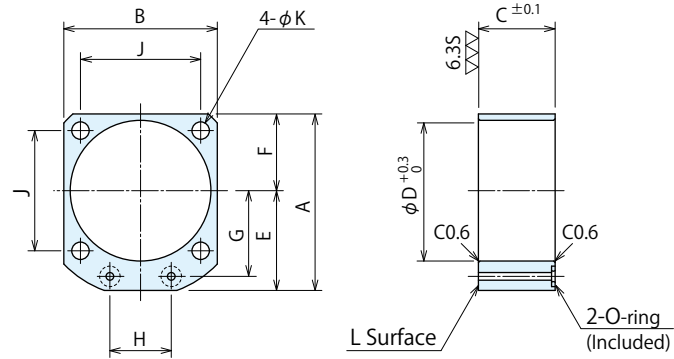

(mm)

Model No.	LZY0360-MD	LZY0400-MD	LZY0480-MD	LZY0550-MD	LZY0650-MD	LZY0750-MD	LZY0900-MD	LZY1050-MD
Corresponding Item	LKA0360 / LKE0360	LKA0400 / LKC0400	LKA0480 / LKC0480	LKA0550 / LKC0550	LKA0650 / LKC0650	LKA0750	LKA0900	LKA1050
Model Number	LHA0360 / LHC0360	LKE0400 / LHA0400	LKE0480 / LHA0480	LKE0550 / LHA0550	LHA0650 / LHC0650	LHA0750	LHA0900	LHA1050
	LHE0360 / LHS0360	LHC0400 / LHE0400	LHC0480 / LHE0480	LHC0550 / LHE0550	LHS0650	LHS0750	LHS0900	LHS1050
	LL0360	LHS0400 / LL0400	LHS0480 / LL0480	LHS0550 / LL0550	LL0650	LL0750	LL0900	LL1050
A	49	54	61	69	81	92	107	122
B	40	45	51	60	70	80	95	110
C	20	20	27	30	32	37	45	50
D	36	40	48	55	65	75	90	105
E	29	31.5	35.5	39	46	52	59.5	67
F	20	22.5	25.5	30	35	40	47.5	55
G	23.5	26	30	33.5	39.5	45	52.5	60
H	16	18	22	24	30	32	37	45
J	31.4	34	40	47	55	63	75	88
K	4.5	5.5	5.5	6.8	6.8	9	11	14
O-ring	1BP5	1BP5	1BP5	1BP5	1BP7	1BP7	1BP7	1BP7
Mass kg	0.2	0.2	0.3	0.4	0.5	0.8	1.2	1.7

- Notes
1. Material: S45C
 2. Mounting bolts are not provided. Prepare mounting bolts according to the mounting height using the C dimensions as a reference.
 3. If thickness other than C is required, perform additional machining on surface L. Please refer to the drawing.

Manifold Block for LM/LJ/LT/LG

Model No. Indication

LZ 048 0 - MS

Size
(Refer to following table)

Design No.
(Revision Number)

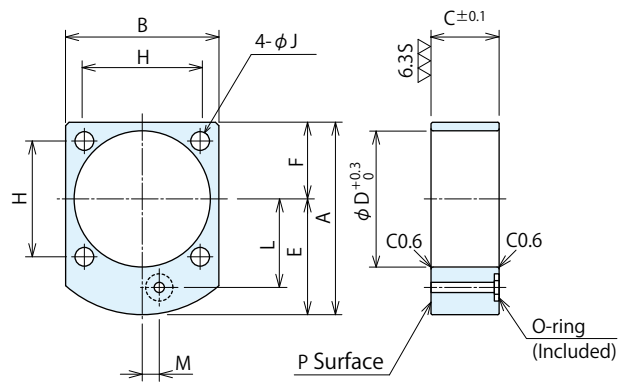

(mm)

Model No.	LZ0360-MS	LZ0400-MS	LZ0480-MS	LZ0550-MS	LZ0650-MS	LZ0750-MS	LZ0900-MS	LZ1050-MS
Corresponding Item	LT0360	LT0400	LT0480	LT0550	LT0650	LT0750	LG0900	LG1050
Model Number	LM0360	LM0400	LM0480	LM0550	LM0650	LM0750	LJ0902	LJ1052
A	51.5	56.5	62	70	82	93	107	122
B	40	45	51	60	70	80	95	110
C	20	20	27	30	32	37	45	50
D	36	40	48	55	65	75	90	105
E	31.5	34	36.5	40	47	53	59.5	67
F	20	22.5	25.5	30	35	40	47.5	55
H	31.4	34	40	47	55	63	75	88
J	4.5	5.5	5.5	6.8	6.8	9	11	14
L	23.5	26	30	33.5	39.5	45	52.5	60
M	5	5	0	0	0	0	0	0
O-ring	1BP5	1BP5	1BP5	1BP5	1BP7	1BP7	1BP7	1BP7
Mass kg	0.2	0.2	0.3	0.4	0.5	0.8	1.2	1.7

- Notes
1. Material: S45C
 2. Mounting bolts are not provided. Prepare mounting bolts according to the mounting height using the C dimensions as a reference.
 3. If thickness other than C is required, perform additional machining on surface L. Please refer to the drawing.

Manifold Block for LC/TC

Model No. Indication

LZ 048 0 - MP

Size
(Refer to following table)

Design No.
(Revision Number)

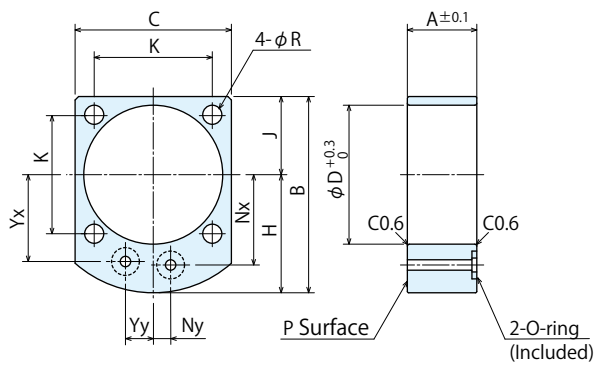

(mm)

Model No.	LZ0400-MP	LZ0480-MP	LZ0550-MP	LZ0650-MP	LZ0750-MP	LZ0900-MP
Corresponding Item	LC0402	LC0482	LC0552	LC0652	LC0752	LC0902
Model Number	TC0402	TC0482	TC0552	TC0652	TC0752	
A	20	27	30	32	37	45
B	56.5	62	70	82	93	107
C	45	51	60	70	80	95
D	40	48	55	65	75	90
H	34	36.5	40	47	53	59.5
J	22.5	25.5	30	35	40	47.5
K	34	40	47	55	63	75
Nx	26	30	33.5	39.5	45	52.5
Ny	5	0	0	0	0	0
R	5.5	5.5	6.8	6.8	9	11
Yx	25	28	31	37	42.5	50
Yy	8	11	13	14	15	15
O-ring	1BP5	1BP5	1BP5	1BP7	1BP7	1BP7
Mass kg	0.2	0.3	0.4	0.5	0.8	1.2

- Notes
1. Material: S45C
 2. Mounting bolts are not provided. Prepare mounting bolts according to the mounting height using the A dimensions as a reference.
 3. If thickness other than A is required, perform additional machining on surface P. Please refer to the drawing.

- High-Power Series
- Pneumatic Series
- Hydraulic Series
- Valve / Coupler Hydraulic Unit
- Manual Operation Accessories**
- Cautions / Others
- Screw Locator
 - VXF
- Manual Expansion Locating Pin
 - VX
- Manifold Block**
 - WHZ-MD
 - LZY-MD
 - LZ-MS
 - LZ-MP**
 - TMZ-1MB
 - TMZ-2MB
 - DZ-M
- Manifold Block / Nut
 - DZ-R
 - DZ-C
 - DZ-P
 - DZ-B
 - LZ-S
 - LZ-SQ
 - TNZ-S
 - TNZ-SQ
- Pressure Switch
 - JB
- Pressure Gauge
 - JGA/JGB
- Manifold
 - JX
- Coupler Switch
 - PS
- G-Thread Fitting

Sales Offices

Sales Offices across the World

Japan	TEL. +81-78-991-5162	FAX. +81-78-991-8787
Overseas Sales	KOSMEK LTD. 1-5, 2-chome, Murotani, Nishi-ku, Kobe-city, Hyogo, Japan 651-2241 〒651-2241 兵庫県神戸市西区室谷2丁目1番5号	
USA	TEL. +1-630-241-3465	FAX. +1-630-241-3834
KOSMEK (USA) LTD.	1441 Branding Avenue, Suite 110, Downers Grove, IL 60515 USA	
China	TEL.+86-21-54253000	FAX.+86-21-54253709
KOSMEK (CHINA) LTD. 考世美(上海)貿易有限公司	21/F, Orient International Technology Building, No.58, Xiangchen Rd, Pudong Shanghai 200122., P.R.China 中国上海市浦东新区向城路58号东方国际科技大厦21F室 200122	
Thailand	TEL. +66-2-715-3450	FAX. +66-2-715-3453
Thailand Representative Office	67 Soi 58, RAMA 9 Rd., Suanluang, Suanluang, Bangkok 10250, Thailand	
Taiwan (Taiwan Exclusive Distributor)	TEL. +886-2-82261860	FAX. +886-2-82261890
Full Life Trading Co., Ltd. 盈生貿易有限公司	16F-4, No.2, Jian Ba Rd., Zhonghe District, New Taipei City Taiwan 23511 台湾新北市中和區建八路2號 16F-4 (遠東世紀廣場)	
Philippines (Philippines Exclusive Distributor)	TEL.+63-2-310-7286	FAX. +63-2-310-7286
G.E.T. Inc, Phil.	Victoria Wave Special Economic Zone Mt. Apo Building, Brgy. 186, North Caloocan City, Metro Manila, Philippines 1427	
Europe (Europe Exclusive Distributor)	TEL. +43-463-287587-10	FAX. +43-463-287587-20
KOS-MECH GmbH	Schleppeplatz 2 9020 Klagenfurt Austria	
Indonesia (Indonesia Exclusive Distributor)	TEL. +62-21-5818632	FAX. +62-21-5814857
P.T PANDU HYDRO PNEUMATICS	Ruko Green Garden Blok Z- II No.51 Rt.005 Rw.008 Kedoya Utara-Kebon Jeruk Jakarta Barat 11520 Indonesia	

Sales Offices in Japan

Head Office	TEL.078-991-5115	FAX.078-991-8787
Osaka Sales Office	〒651-2241 兵庫県神戸市西区室谷2丁目1番5号	
Overseas Sales		
Tokyo Sales Office	TEL.048-652-8839	FAX.048-652-8828
	〒331-0815 埼玉県さいたま市北区大成町4丁目81番地	
Nagoya Sales Office	TEL.0566-74-8778	FAX.0566-74-8808
	〒446-0076 愛知県安城市美園町2丁目10番地1	
Fukuoka Sales Office	TEL.092-433-0424	FAX.092-433-0426
	〒812-0006 福岡県福岡市博多区上牟田1丁目8-10-101	

Global Network



Asia Detailed Map

